

ZEROSTART®

COLD WEATHER STARTING PRODUCTS

2011 Cold Weather Starting Products Application Guide & Product Catalog

Weatherly Index #244

Due to our constant efforts to provide the most accurate and complete information possible, the information presented in this publication is subject to change. To be sure you have the most current information, visit our website

www.phillipsandtemro.com

If there are any new product or application updates, you can download replacement pages and/or entire catalog files from the website. If you require additional information regarding Phillips & Temro Industries products and services, please check our website, or call Customer Service at the numbers below.

Phillips & Temro Industries

9700 West 74th Street
Eden Prairie, MN 55344
(800) 328-6108
(952) 941-9700 • Fax (952) 941-2285



PHILLIPS & TEMRO INDUSTRIES
Eden Prairie, MN
Winnipeg, MB

CONTENTS

Applications Automotive	5-26
<i>Listings begin on page #</i>	
Acura, AMC, Audi, BMW, Buick	6-8
Cadillac	8
Chevrolet	9-10
Chrysler	11
Dodge Light-Medium Duty Trucks & Vans	11-12
Daewoo, Eagle, Fiat, Ford/Mercury	12-14
Geo, Honda	14-15
Hummer, Hyundai, Infiniti	15-16
International by Navistar, Isuzu, Jaguar	16-17
Kia, Lada, Lexus	17-18
Mazda, Mercedes-Benz, Mini, Mitsubishi	18-20
Nissan, Oldsmobile	20-22
Pontiac, Porsche, Land Rover, Sab, Saturn	22-24
Scion, Smart, Subaru, Suzuki	24
Toyota	24-25
Volkswagen, Volvo	25-26
Automotive Footnotes	26
Applications Agricultural, Heavy Duty & Industrial App.	27-65
Allis Chalmers, Belarus, Bolens,	28-29
David Brown, Case IH/JI Case	29
Caterpillar	30-33
Chevrolet, Continental (Teledyne)	33-34
Cummins	33-37
Detroit Diesel	37-40
Deutz-Allis, FAHR, Fiat	40-41
Ford	41-44
Hercules, Hino, International by Navistar	44-48
Isuzu, Iveco	48-50
John Deere	50-51
Komatsu, Kubota	52-54
Lister-Petter, Lombardini, Mack	54-56
Massey & Massey Fergusson	56-57
Mercedes, Minneapolis Moline, Mitsubishi	57-58
Mitsubishi Fuso, MWM Murphy	59
Nissan	59-60
Oliver, Onan, Paccar, Perkins	60-62
Toyota	63
UD Trucks, Volkswagen, Volvo	64-65
Yanmar, Zetor	65
Product Information	66-86
Threaded Oil Pan Heaters, Threaded Coolant Immersion Heaters	66
Cab & Cargo Heaters	67-68
Cab Power System	69
.....	70
Circulation Heaters	71-73
Battery Heaters	74
Cordsets & Accessories	75-78
Freeze Plug Replacement Cordsets	75
Heavy-Duty Immersion Heater Replacement Cordsets	75
Weatherproof Cordsets & Receptacles	76
Y-Cords & Thermostats	77
Indicator Light System	78
Integrated Indicator Light	79
Diesel Fuel Heaters	80
Diesel Starting Fluid Systems	81-84
Interior Warmers	84
Lower Radiator Hose Heaters	85
Magnetic Heaters	85
Radiant Heaters	85
Specialty Products - Vibra® Dump Body Vibrator	86
Engine Startability Chart	87
Technical Information	88
Warranty Information	89-90

FREEZE PLUG HEATERS

The choice of professional installers

- Ensure quick winter starts - reduce engine wear
- Highest rated, most efficient type of heater
- V-Loc™ locking system provides quick, trouble-free installation
- Plated stamped-steel & forged brass adapters with copper heating element for maximum life and efficiency.
- Direct OEM replacement in many applications
- Replaceable cordset

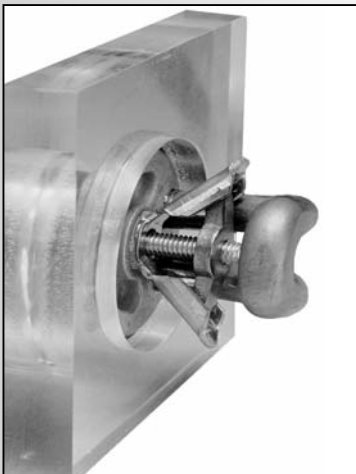

V-Loc™ in fully open position, prior to tightening locking bolt.

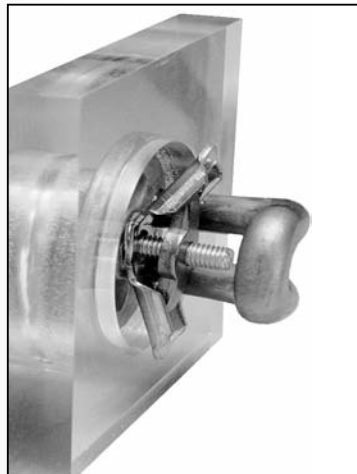

V-Loc™ clamp spreads outward as locking bolt it tightened.



V-Loc™ in fully locked position. Heater is secured in engine block.

See pages 6-26 for Automotive Freeze Plug Applications and pages 27-65 for Agricultural, Heavy Duty, and Industrial Applications.

Replacement cordset information - see Automotive Applications and page 75.

CHAUFFE-MOTEURS

Le choix des installateurs professionnels

- Pour assurer des démarrages rapides en hiver et réduire l'usure du moteur
- Le réchauffeur le mieux coté et le plus efficace
- Le système de verrouillage V-Loc™ permet une installation simple et sans problème
- Adaptateurs en laiton forgé et en acier estampé plaqué avec élément chauffant en cuivre pour une durabilité et une efficacité maximales
- Remplacement direct d'équipement d'origine dans plusieurs applications
- Cordon amovible remplaçable

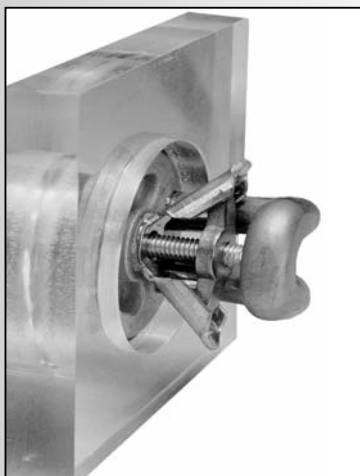

V-Loc™ en position ouverte avant de serrer le boulon d'arrêt.

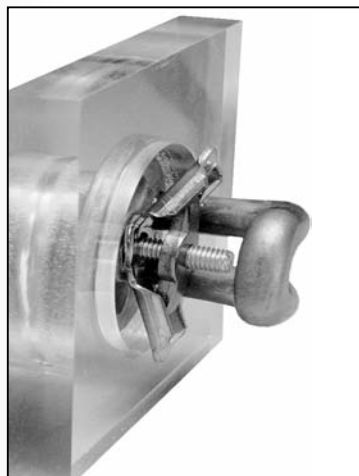

La fixation V-Loc™ s'ouvre vers l'extérieur quand on serre le boulon d'arrêt.



V-Loc™ en position complètement verrouillé. Le réchauffeur est fixé au bloc-moteur.

Consultez les pages 6 à 26 pour connaître les applications du chauffe-moteur pour automobiles et les pages 27 à 65 pour les applications de machinerie agricole, lourde et industrielle.

Information sur le cordon amovible de rechange - consultez la rubrique applications pour automobiles et la page 75.

Automotive & light-duty Truck Applications

See page 27 for Agricultural, Heavy Duty, and Industrial Applications.

All automotive applications are CSA approved.



Automotive/light-duty truck listings appear as follows:

Year(s), type of engine, size/model of engine, possible additional information.

1956-62 V8 327 CID	3100039	3600006	1-1/2"	LC or RC	6 o'clock	1	3200003	1500W
--------------------	---------	---------	--------	----------	-----------	---	---------	-------

Immersion/Freeze Plug Heater part number
"NONE" indicates item not currently available.

Replacement Cord Part Number
Also see page 75 for replacement cord information.

Bore Diameter
Freeze Plug Heaters will list a size similar to the above heater (English or metric). Threaded type heaters will list "THD" after the size. Heaters with NPT threads will list "NPT" after the size. "Clampon" entry indicate that a frost plug or threaded type heater is not available for a particular engine; an external bolt-on heater may be used instead.

Installation location
Use chart below to assure proper installation location.

Point element
Use the clock position listed to determine the direction the element should point. "N/A" entry indicates a threaded heater with no element bend, or recommended heater has no requirements for element direction.

Notes
If a number appears in this column, see page 26 for important information regarding application.

Lower Radiator Hose Heater part number
If your vehicle can use a LRHH as a heating option, the part number will appear here. In some cases, a radiator hose heater is the only heating option.

Circulation/Tank Wattage
If a Circulation or Tank type heater can be used, the recommended wattage of the heater will appear in this column.

Where a Freeze Plug style heater is specified, use the chart below to determine the proper mounting location. Unless otherwise noted, freeze plugs are numbered from front.

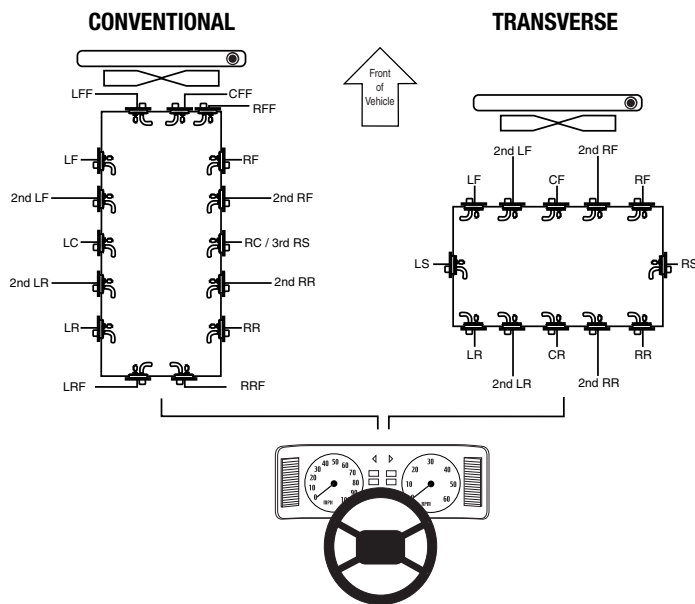

- CFFCenter Front Face
- CFCenter Front
- CRCenter Rear
- FFront
- FFFront Face of Block
- LCLeft Center
- LFLeft Front
- 2nd LF2nd from Left, Front
- LFFFront Face, Left Cylinder
- LLCLeft Side, Lower Center
- LRLeft Rear
- 2nd LR2nd from Left, Rear
- LSLeft Side
- RRear
- RCRight Center
- RearRear Face or Side
- RFRight Front
- 2nd RF2nd from Right Front
- RFFFront Face, Right Cylinder Head
- RRRight Rear
- RSRight Side
- 3rd RS3rd from Firewall (FW) Right Side
- 2nd RR2nd Core Hole from the Right Rear

Automotive Applications:

Diagram shown from driver's seat view.

Applications automobiles et camions légers

Consultez la page 27 pour les applications de
machinerie agricole, lourde et industrielle.

Toutes les applications automobiles
sont approuvées par la CSA.



Les listes pour automobiles et camions légers sont présentées comme suit :

Année(s), type de moteur, puissance/modèle du moteur, renseignements supplémentaires possibles.

1956-62 V8 327 cc 3100039 3600006 38,1 mm (1,5 po) CG ou CD 6 h 1 3200003 1500 W

Numéro de pièce du thermoplongeur/chauffe-moteur
« AUCUN » signifie que l'article n'est pas offert actuellement.

Numéro de pièce du cordon de recharge
Consultez également la page 75 pour de l'information sur le cordon de recharge.

Diamètre de l'alésage
Pour les chauffe-moteurs, une taille semblable à celle du réchauffeur ci-dessus sera indiquée (unités anglaises ou métriques). Pour les réchauffeurs filetés, « FIL » sera indiqué après la taille. Pour les réchauffeurs à filetage NPT, « NPT » sera indiqué après la taille. La mention « Boulonné » indique qu'il n'y a pas de chauffe-moteur ou de réchauffeur fileté pour ce moteur; un réchauffeur externe boulonné pourrait être utilisé.

Site d'installation
Utilisez le graphique ci-dessous pour vous assurer du site d'installation approprié.

Orientation de l'élément
Utilisez la position horaire inscrite pour établir la direction dans laquelle l'élément doit être orienté. « S.O. » indique un réchauffeur fileté sans courbure de l'élément ou un réchauffeur recommandé sans exigences relatives à l'orientation.

Remarques
Si un numéro apparaît dans cette colonne, consultez la page 26 pour des renseignements importants concernant l'utilisation.

Numéro de pièce du réchauffeur de durite de radiateur inférieure
Si votre véhicule peut utiliser un réchauffeur de durite de radiateur inférieure, le numéro de pièce apparaîtra ici. Dans certains cas, un réchauffeur de durite de radiateur est le seul type de chauffage possible.

Puissance du réchauffeur de circuit/chauffe-réservoir
Si un réchauffeur à circulation ou un chauffe-réservoir peut être utilisé, la puissance recommandée du réchauffeur apparaîtra dans cette colonne.

Si un chauffe-moteur est indiqué, utilisez le graphique ci-dessous pour déterminer l'emplacement approprié pour le montage.
À moins d'indication contraire, les chauffe-moteurs sont numérotés sur le devant.

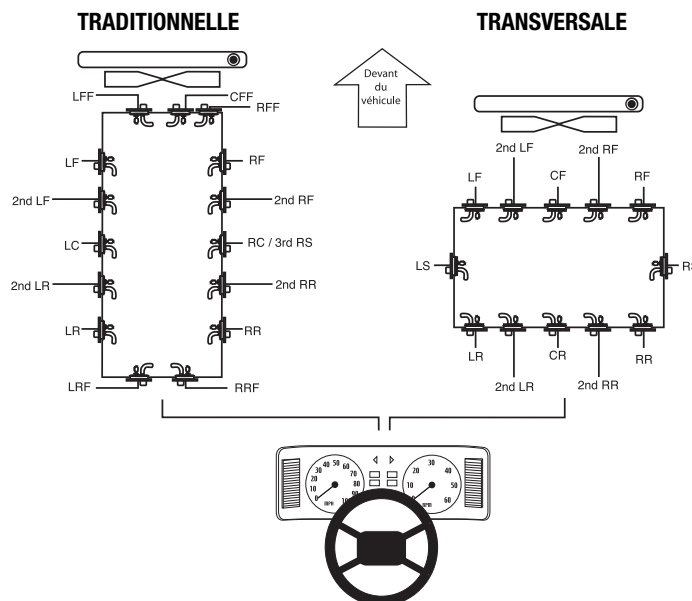

- CFFFace avant au centre
- CFAvant au centre
- CRArrière au centre
- FAvant
- FFFace avant du bloc
- LCCentre gauche
- LFGauche avant
- 2nd LF2e de la gauche, avant
- LFFFace avant, cylindre gauche
- LLCCôté gauche, centre inférieur
- LRGauche arrière
- 2nd LR2e de la gauche arrière
- LSCôté gauche
- RArrière
- RCCentre droit
- RearArrière
- RFDroite avant
- 2nd RF2e de la droite avant
- RFFFace avant, culasse droite
- RRDroite arrière
- RSCôté droit
- 3rd RS3e de la cloison pare-feu (CD) côté droit
- 2nd RR2e bouchon de la droite arrière

Applications automobiles :

Le schéma est montré du point de vue du siège du conducteur.

MAKE, MODEL, YEAR & ENGINE	FREEZE PLUG HEATER (UNLESS OTHERWISE NOTED)						LOWER HOSE HEATER	CIRCULATION HEATER
	HEATER PART No.	REPL. CORD PART No.	BORE DIAMETER	INSTALLATION LOCATION	POINT ELEMENT†	NOTES*	PART No.	WATTAGE
ACURA								
4 Cylinder								
1996-2000 L4 - 1.6L	3100006	3600005	28 MM THD	LR	N/A		N/A	N/A
1987-89 L4 - 1.6L	3400001	3600002	CLAMP-ON	N/A	N/A		N/A	N/A
2002-2005 L4 - 1.7L	3100006	3600005	28 MM THD	LR	N/A		N/A	N/A
1990-2001 L4 - 1.7, 1.8L	3100006	3600005	28 MM THD	RF	N/A		N/A	N/A
2002-2006 L4 - 2.0L [RSX]	3100006	3600005	28 MM THD	RR	N/A		N/A	N/A
2006-2011 L4 - 2.0L [CSX]	3100006	3600005	28 MM THD	RR	N/A		N/A	N/A
1995-97 L4 - 2.2L [CL Coupe]	3100006	3600005	28 MM THD	LR	N/A		N/A	N/A
1998-99 L4 - 2.3L [CL Coupe]	3100006	3600005	28 MM THD	LR	N/A		N/A	N/A
2004-2011 L4 - 2.4L [TSX]	see dealer	N/A	N/A	N/A	N/A		N/A	N/A
5 Cylinder								
1992-98 L5 - 2.5L	3100006	3600005	28 MM THD	RF	N/A		N/A	N/A
6 Cylinder								
1987-90 V6 - 2.5, 2.7L	see dealer		N/A	N/A	N/A		N/A	N/A
1991-99 V6 - 3.2L	3100006	3600005	28 MM THD	LC	N/A		N/A	N/A
1993-2005 V6 - 3.0, 3.2L [NSX]	see dealer	N/A	N/A	N/A	N/A		N/A	N/A
1997-99 V6 - 3.0L [CL coupe]	3100006	3600005	28 MM THD	LF	N/A		N/A	N/A
1999-2007 V6 - 3.2 [TL, CL coupe]]	3100006	3600005	28 MM THD	LF	N/A		N/A	N/A
2007-2010 V6 - 3.5L [TL Type S]	3100006	3600005	28 MM THD	LF	N/A		N/A	N/A
1996-2004 V6 - 3.5 [RL]	3100006	3600005	28 MM THD	LF	N/A		N/A	N/A
2005-2011 V6 - 3.5L [RL]	3100006	3600005	28 MM THD	LF	N/A		N/A	N/A
2009-2011 V6 - 3.7L [TL]	3100006	3600005	28 MM THD	LF	N/A		N/A	N/A
LIGHT TRUCK								
2007-2010 L4 - 2.3L [RDX]	3100006	3600005	28 MM THD		N/A		N/A	N/A
1998-00 V6 - 3.5L	see dealer	N/A	N/A	N/A	N/A		N/A	N/A
2001-2006 V6 - 3.5L [MDX]	3100006	3600005	28 MM THD	LF	N/A		N/A	N/A
2007-2011 V6 - 3.7L [MDX]	3100006	3600005	28 MM THD	LF	N/A		N/A	N/A
AMC - EXCEPT JEEP AND EAGLE								
4 Cylinder								
1984 L4 - 2.5L	3100065	3600006	1-3/4"	LR	6 o'clock		320-0003	750W
1980-83 L4 - 2.5L (Pontiac engine)	3100054	3600006	1-5/8"	LR	12 o'clock		320-0003	750W
6 Cylinder								
1964-87 L6 - 199, 232, 258 cu. in. (4.2L)	3100072	3600006	2"	LR	12 o'clock		320-0003	750W
8 Cylinder								
1956-62 V8 - 327 cu. in.	3100039	3600006	1-1/2"	LC or RC	6 o'clock		320-0003	1500W
1966-80 V8 - 290, 304, 343, 360, 390, 401 cu. in.	3100039	3600006	1-1/2"	LR	5 o'clock		320-0003	1500W
AUDI								
4 Cylinder								
1973-88 L4 - 1471cc	3100034	3600016	36.5 MM	2ND RS	6 o'clock		N/A	N/A
1986-90 L4 - 1.8, 2.0L	3100034	3600016	36.5 MM	RC	6 o'clock		N/A	N/A
1997-2005 L4 - 1.8L (TURBO)	see dealer	N/A	N/A	N/A	N/A		N/A	N/A
2005-2011 L4 - 2.0L (TURBO FSI & TSI)	see dealer	N/A	N/A	N/A	N/A		N/A	N/A
2010-2011 L4 - 2.0L DIESEL	see dealer	N/A	N/A	N/A	N/A		N/A	N/A
5 Cylinder								
1980-86 L5 - 2.0L, 2.1L & 2.2L (Except TURBO)	3100034	3600016	36.5 MM	RC	6 o'clock		N/A	N/A
1987-95 L5 - 2.2, 2.3L	3100035	3600016	36.5 MM	RF or 2ND RF	3 o'clock		N/A	N/A
6 Cylinder								
1992-95 V6 - 2.8L	see dealer	N/A	N/A	N/A	N/A		N/A	N/A
1996-2001 V6 - 2.8L	see dealer	N/A	N/A	N/A	N/A		N/A	N/A
2000-2004 V6 - 2.7L (TURBO)	see dealer	N/A	N/A	N/A	N/A		N/A	N/A
2002-2005 V6 - 3.0L	see dealer	N/A	N/A	N/A	N/A		N/A	N/A
2009-2011 V6 - 3.0L Supercharged	see dealer	N/A	N/A	N/A	N/A		N/A	N/A
2010-2011 V6 - 3.0L DIESEL	see dealer	N/A	N/A	N/A	N/A		N/A	N/A
2004-2009 V6 - 3.2L (Transverse)	see dealer	N/A	N/A	N/A	N/A		N/A	N/A
2005-2011 V6 - 3.2L (Conventional)	see dealer	N/A	N/A	N/A	N/A		N/A	N/A
2006-2010 V6 - 3.6L	see dealer	N/A	N/A	N/A	N/A		N/A	N/A
8 Cylinder								
2011 V8 - 4.0 Supercharged	see dealer	N/A	N/A	N/A	N/A		N/A	N/A
1992-2011 V8 - 3.6, 3.7, 4.2L	see dealer	N/A	N/A	N/A	N/A		N/A	N/A
10 Cylinder								
2006-2011 V10 - 5.2L	see dealer	N/A	N/A	N/A	N/A		N/A	N/A
12 Cylinder								
2006-2009 W12 - 6.0L	see dealer	N/A	N/A	N/A	N/A		N/A	N/A
2011 W12 - 6.2L	see dealer	N/A	N/A	N/A	N/A		N/A	N/A

† Please confirm element orientation - improper position may result in heater or engine damage.

* Description of footnotes - see page 26. Circulation Heaters - see page 71. Lower Radiator Hose Heaters - see page 85.

MAKE, MODEL, YEAR & ENGINE	FREEZE PLUG HEATER (UNLESS OTHERWISE NOTED)					LOWER HOSE HEATER	CIRCULATION HEATER	
	HEATER PART No.	REPL. CORD PART No.	BORE DIAMETER	INSTALLATION LOCATION	POINT ELEMENT†	NOTES*	PART No.	WATTAGE
BMW								
4 Cylinder								
1969-90 L4 - SOHC	3100030	3600006	36 MM	RC	6 o'clock		N/A	750W
6 Cylinder								
1978-83 L6 - ALL (Except 528E)	3100030	3600006	36 MM	LF	3 o'clock		N/A	750W
1982-91 L6 - 2.5, 2.7, 3.5L	3100063	3600006	44 MM	2ND RF	4 o'clock		N/A	N/A
1992-99 24-Valve L6- 2.0, 2.5, 2.8, 3.0, 3.2L	see dealer	N/A	N/A	N/A	N/A		N/A	N/A
1998-2005 24-Valve L6 - 2.8, 3.0, 3.2, 3.4L (Aluminum Block)	see dealer	N/A	N/A	N/A	N/A		N/A	N/A
2006-2011 L6 - 3.0L	see dealer	N/A	N/A	N/A	N/A		N/A	N/A
2007-2010 L6 - 3.0L (N54) Twin Turbo	see dealer	N/A	N/A	N/A	N/A		N/A	N/A
2010-2011 L6 - 3.0L (N55) Turbo	see dealer	N/A	N/A	N/A	N/A		N/A	N/A
2010-2011 L6 - 3.0L Diesel	see dealer	N/A	N/A	N/A	N/A		N/A	N/A
8 Cylinder								
1993-2009 V8 - 3.0, 4.0, 4.4, 4.6, 4.8, 5.0L	see dealer	N/A	N/A	N/A	N/A		N/A	N/A
2008-2011 V8 - 4.0L (S65B40)	see dealer	N/A	N/A	N/A	N/A		N/A	N/A
2009-2011 V8 - 4.4L Turbo	see dealer	N/A	N/A	N/A	N/A		N/A	N/A
10 Cylinder								
2006-2009 V10 - 5.0L (S65B50)	see dealer	N/A	N/A	N/A	N/A		N/A	N/A
12 Cylinder								
1988-2003 V12 - 5.0, 5.4L	see dealer	N/A	N/A	N/A	N/A		N/A	N/A
2004-2008 V12 - 6.0L	see dealer	N/A	N/A	N/A	N/A		N/A	N/A
2010-2011 V12 - 6.0L Turbo	see dealer	N/A	N/A	N/A	N/A		N/A	N/A
BUICK								
4 Cylinder								
1982-86 L4 - 1.8L	3100014	3600006	34 MM	LF	12 o'clock		N/A	N/A
1983-89 L4 - 1.8, 2.0L OHC (Brazil engine)	3100015	3600006	34 MM	2ND LF	3 o'clock		N/A	N/A
1983-84 L4 - 2.0L	3100014	3600006	34 MM	LF	12 o'clock		N/A	N/A
1985-86 L4 - 2.0L	3100062	3600006	42 MM	LF	4 o'clock		N/A	N/A
1987-96 L4 - 2.0L, 2.2L (Transverse)	3100081	3600006	42 MM	LF	9 o'clock		N/A	N/A
2011 L4 - 2.0L Turbo	see dealer	N/A	N/A	N/A	N/A		N/A	N/A
1987-93 L4 - 2.3L QUAD IV	3100093	3600006	3/4" NPT	N/A	N/A		N/A	N/A
1994-95 L4 - 2.3L QUAD IV GEN II	3100001	3600006	1/2" NPT	In water pump	N/A		N/A	N/A
1996-99 L4 - 2.4L (Twin Cam)	3100001	3600006	1/2" NPT	In water pump	N/A		N/A	N/A
2011 L4 - 2.4L Ecotec	see dealer	N/A	N/A	N/A	N/A		N/A	N/A
1980-92 L4 - 2.5L	3100076	3600006	1-5/8"	LF	12 o'clock		320-0003	750W
6 Cylinder								
1980-86 V6 - 2.8L (Transverse) Except VIN W	3100014	3600006	34 MM	RS	3 o'clock		320-0003	N/A
1987-89 V6 - 2.8L (Transverse) VIN W	3100015	3600006	34 MM	CR	3 o'clock		N/A	N/A
1982-88 V6 - 3.0L (Transverse)	3100041	3600006	1-1/2"	LF	12 o'clock		320-0003	1000W
2010-2011 V6 - 3.0L (Transverse)	see dealer	N/A	N/A	N/A	N/A		N/A	N/A
1989-2004 V6 - 3.1L (Transverse)	3100015	3600006	34 MM	CR	3 o'clock		N/A	N/A
2005-2007 V6 - 3.1L (Transverse)	see dealer	N/A	N/A	N/A	N/A		N/A	N/A
2002-2003 V6 - 3.4L (Transverse)	3100015	3600006	34 MM	CR	3 o'clock		N/A	N/A
1978-79 V6 - 196 cu. in.	3100039	3600006	1-1/2"	RR	12 o'clock		320-0003	1000W
2005-2011 V6 - 3.6L (Transverse)	3100110	3600082	Cartridge	LR	N/A		N/A	N/A
1988-2004 V6 - 3300, 3800 (Transverse)	3100041	3600006	1-1/2"	RF or LF	12 o'clock		320-0003	N/A
2005-2009 V6 - 3800 (Transverse)	3100109	3600082	28 MM THD	CR	N/A		N/A	N/A
1975-88 V6 - 3.8L (231 cu. in.) (Conventional)	3100039	3600006	1-1/2"	RR	12 o'clock		320-0003	1000W
1984-88 V6 - 3.8L (231 cu. in.) (Transverse)	3100041	3600006	1-1/2"	RF or LF	3 o'clock		320-0003	750W
2009-2011 V6 - 3.9L (Transverse)	3100109	3600006	28 MM THD	CR	N/A		N/A	N/A
1980-85 V6 - 4.1L (252 cu. in.)	3100039	3600006	1-1/2"	RR	12 o'clock		320-0003	750W
1982-85 V6 - 4.3L (265 cu. in.) DIESEL (Conv)	3100039	3600006	1-1/2"	LF or RF	12 o'clock		320-0003	1000W
1982-85 V6 - 4.3L (263 cu. in.) DIESEL (Transverse)	3100039	3600006	1-1/2"	RR or RF	12 o'clock		N/A	1000W
1968-76 L6 - 250 cu. in.	3100054	3600006	1-5/8"	LR	12 o'clock		320-0003	1000W
8 Cylinder								
1975-76 V8 - 260 cu. in.	3100039	3600006	1-1/2"	RF	6 o'clock		320-0003	1000W
1981-82 V8 - 4.4L (267 cu. in.)	3100057	3600006	1-5/8"	LR	9 o'clock		320-0003	1000W
1977-82 V8 - 4.3 L (265 cu. in.) 4.9L (301 cu. in.)	3100070	3600006	1-15/16"	LC	11 o'clock		320-0003	1000W
2006-2011 V8 - 4.6L (North Star)	see dealer	3600082	N/A	N/A	N/A		N/A	N/A
1977-95 V8 - 5.0L (305 cu. in.) (Chevrolet engine)	3100057	3600006	1-5/8"	LR	9 o'clock		320-0003	1500W
1981-91 V8 - 5.0L (307 cu. in.) (Oldsmobile engine)	3100039	3600006	1-1/2"	LF or RF	12 o'clock		320-0003	1500W
2008-2009 V8 - 5.3L (Transverse)	3100109	3600082	28 MM THD	RF	N/A		N/A	N/A
1968-81 V8 - 5.7L (350 cu. in.) (Buick engine)	3100039	3600006	1-1/2"	LF or RR	12 o'clock		320-0003	1500W
1980-85 V8 - 5.7L (350 cu. in.) DIESEL	3100039	3600006	1-1/2"	LF or RF	12 o'clock		N/A	1500W
1991-96 V8 - 5.0L (305 cu. in.), 5.7L (350 cu. in.)	3100057	3600006	1-5/8"	LR	9 o'clock		320-0003	1500W

† Please confirm element orientation - improper position may result in heater or engine damage.

* Description of footnotes - see page 26. Circulation Heaters - see page 71. Lower Radiator Hose Heaters - see page 85.

MAKE, MODEL, YEAR & ENGINE	FREEZE PLUG HEATER (UNLESS OTHERWISE NOTED)						LOWER HOSE HEATER	CIRCULATION HEATER
	HEATER PART No.	REPL. CORD PART No.	BORE DIAMETER	INSTALLATION LOCATION	POINT ELEMENT†	NOTES*	PART No.	WATTAGE
BUICK - continued								
(Chevrolet engine)								
1975-77 V8 - 400 cu. in.	3100070	3600006	49 MM	LF	12 o'clock		320-0003	1500W
1977-79 V8 - 403 cu. in.	3100039	3600006	1-1/2"	RF	12 o'clock		320-0003	1500W
1967-71 V8 - 430, 455 cu. in.	3100039	3600006	1-1/2"	RC	12 o'clock		320-0003	1500W
LIGHT DUTY TRUCKS								
6 Cylinder								
2002-2004 V6 - 3.4L	3100015	3600006	34 MM	CR	3 o'clock		N/A	N/A
2005-2006 V6 - 3.4L	see dealer	N/A	N/A	N/A	N/A		N/A	N/A
2004 V6 - 3.5L	3100005	3600005	28 MM THD	CR	N/A		N/A	N/A
2004 V6 - 3.6L (Transverse)	3100106	3600083	Cartridge	LR	N/A		N/A	N/A
2005-2011 V6 - 3.6L (Transverse)	3100110	3600082	Cartridge	LR	N/A		N/A	N/A
2001-2003 V6 - 3800 (Transverse)	3100041	3600006	1-1/2"	RF or LF	12 o'clock		320-0003	N/A
2003-2004 L6 - 4.2L (Conventional)	3100005	3600005	28 MM THD	LF	N/A		N/A	N/A
2005-2007 L6 - 4.2L (Conventional)	3100109	3600082	28 MM THD	LF	N/A		N/A	N/A
8 Cylinder								
2003-2004 V8 - 5.3L (Conventional)	3100005	3600005	28 MM THD	LR	N/A		N/A	N/A
2005-2007 V8 - 5.3L (Conventional)	3100109	3600082	28 MM THD	LR	N/A		N/A	N/A
CADILLAC								
4 Cylinder								
1982-84 L4 - 1.8, 2.0L	3100014	3600006	34 MM	LF	12 o'clock		N/A	N/A
1985-88 L4 - 2.0L	3100062	3600006	42 MM	LF	4 o'clock		N/A	N/A
6 Cylinder								
1985-86 V6 - 2.8L (Transverse)	3100014	3600006	34 MM	RS	3 o'clock		320-0003	N/A
2005-2007 V6 2.8L (Conventional)	3100110	3600082	Cartridge	RR	N/A		N/A	N/A
1997-2001 V6 - 3.0L	3100006	3600005	28 MM	N/A	N/A		N/A	N/A
2010-2011 V6 - 3.0L	see dealer	N/A	N/A	N/A	N/A		N/A	N/A
2002-2004 V6 - 3.2L	3100006	3600006	28 MM	LR	N/A		N/A	N/A
2005-2006 V6 - 3.2L	see dealer	N/A	N/A	N/A	N/A		N/A	N/A
1986-88 V6 - 2.8L (Transverse) VIN W	3100015	3600006	34 MM	CR	3 o'clock		N/A	N/A
2004 V6 - 3.6L (Conventional)	3100106	3600083	Cartridge	RR	N/A		N/A	N/A
2005-2011 V6 - 3.6L (Conventional)	3100110	3600082	Cartridge	RR	N/A		N/A	N/A
1981-82 V6 - 4.1L (252 cu. in.)	3100039	3600006	1-1/2"	RR	12 o'clock		N/A	1000W
1984-85 V6 - 4.3L (262 cu. in.) DIESEL	3100039	3600006	1-1/2"	RF or RR	12 o'clock		N/A	1000W
8 Cylinder								
1982-94 V8 - 4.1, 4.5, 4.9L (Transverse)	see dealer	N/A	CLAMP-ON	N/A	N/A		320-0003	N/A
1993-2011 V8 - 4.6L (Transverse) [Northstar]	see dealer	N/A	CLAMP-ON	N/A	N/A		N/A	N/A
2005-2009 V8 - 4.4L (Conventional) [Northstar SC]	3100109	3600082	28 MM THD	RC	N/A		N/A	N/A
2004 V8 - 4.6L (Conventional) [Northstar]	3100005	3600005	28 MM THD	RC	N/A		N/A	N/A
2005-2010 V8 - 4.6L (Conventional) [Northstar]	3100109	3600082	28 MM THD	RC	N/A		N/A	N/A
1986-92 V8 - 5.0L (307 cu. in.)	3100039	3600006	1-1/2"	LF or RF	12 o'clock		320-0003	1500W
1990-96 V8 - 5.0, 5.7L (Chevrolet engine)	3100057	3600006	1-5/8"	LR	9 o'clock		320-0003	N/A
1976-81 V8 - 5.7L (350 cu. in.)	3100039	3600006	1-1/2"	LC or RC	12 o'clock		320-0003	1500W
1978-85 V8 - 5.7L (350 cu. in.) DIESEL	3100039	3600006	1-1/2"	LF or RF	12 o'clock		N/A	750W
2004 V8 - 5.7L [CTS-V]	3100005	3600005	28 MM THD	LF	N/A		N/A	N/A
2005-2007 V8 - 5.7L [CTS-V]	3100109	3600082	28 MM THD	LF	N/A		N/A	N/A
1980-84 V8 - 6.0L (368 cu. in.)	3100065	3600006	1-3/4"	RC	12 o'clock		N/A	750W
2009-2011 V8 - 6.2L (LSA) [CTS-V]	3100109	3600082	28 MM THD	LF	N/A		N/A	N/A
1977-79 V8 - 425 cu. in.	3100065	3600006	1-3/4"	RC	11 o'clock		320-0003	750W
1968-76 V8 - 472, 500 cu. in.	3100065	3600006	1-3/4"	LF or RC	12 o'clock		320-0003	750W
LIGHT DUTY TRUCKS								
6 Cylinder								
2010-2011 V6 - 2.8L Turbo	see dealer	N/A	N/A	N/A	N/A		N/A	N/A
2010-2011 V6 - 3.0L	see dealer	N/A	N/A	N/A	N/A		N/A	N/A
2004 V6 - 3.6L (Conventional)	3100106	3600083	Cartridge	RR	N/A		N/A	N/A
2005-2009 V6 - 3.6L (Conventional)	3100110	3600082	Cartridge	RR	N/A		N/A	N/A
8 Cylinder								
2004 V8 - 4.6L (Conventional) [Northstar]	3100005	3600005	28 MM THD	RC	N/A		N/A	N/A
2005-2009 V8 - 4.6L (Conventional) [Northstar]	3100109	3600082	28 MM THD	RC	N/A		N/A	N/A
2001-2004 V8 - 5.3, 6.0L	3100005	3600005	28 MM THD	LR	N/A		N/A	N/A
2005-2006 V8 - 5.3, 6.0L	3100109	3600082	28 MM THD	LR	N/A		N/A	N/A
2009-2011 V8 - 6.0L Hybrid	3100109	3600082	28 MM THD	LF	N/A		N/A	N/A
2007-2011 V8 - 6.2L	3100109	3600082	28 MM THD	LF	N/A		N/A	N/A

† Please confirm element orientation - improper position may result in heater or engine damage.

* Description of footnotes - see page 26. Circulation Heaters - see page 71. Lower Radiator Hose Heaters - see page 85.

MAKE, MODEL, YEAR & ENGINE	FREEZE PLUG HEATER (UNLESS OTHERWISE NOTED)						LOWER HOSE HEATER	CIRCULATION HEATER
	HEATER PART No.	REPL. CORD PART No.	BORE DIAMETER	INSTALLATION LOCATION	POINT ELEMENT†	NOTES*	PART No.	WATTAGE
CHEVROLET (Also see Geo)								
AUTOMOTIVE								
3 Cylinder								
1986-88 L3 - 1.0L	3400002	3600002	CLAMP-ON	N/A	N/A		320-0001	N/A
1998-00 L3 - 1.0L	3400002	3600002	CLAMP-ON	N/A	N/A		320-0001	N/A
4 Cylinder								
1998-99 L4 - 1.3L (Suzuki engine)	3400004	3600020	CLAMP-ON	N/A	N/A		N/A	N/A
1976-87 L4 - 1.4, 1.6L (Conventional)	3100014	3600006	34 MM	RF	6 o'clock		N/A	N/A
2011 L4 - 1.4L	see dealer	N/A	Oil Pan Heater	N/A	N/A		N/A	N/A
1985-88 L4 - 1.5L (Transverse) Spectrum	3100018	3600006	35 MM	CR	12 o'clock		N/A	N/A
2004-2008 L4 - 1.6L [Aveo]	3100008	3600003	36 MM THD	LF	N/A		N/A	N/A
1985-88 L4 - 1.6L (Transverse) Nova	3100049	3600006	40 MM	CF	6 or 12 o'clock		N/A	N/A
1982-84 L4 - 1.8L (Transverse)	3100014	3600006	34 MM	LF	12 o'clock		N/A	N/A
1982-87 L4 - 1.8L DIESEL	3100018	3600006	35 MM	RR	12 o'clock		N/A	N/A
1998-2002 L4 - 1.8L (Toyota Eng.) (Prizm)	see dealer	N/A	Cartridge	N/A	N/A		N/A	N/A
2011 L4 - 1.8L	see dealer	N/A	Oil Pan Heater	N/A	N/A		N/A	N/A
1983-84 L4 - 2.0L (122 cu. in.) (Transverse)	see dealer	N/A	34 MM	LF	12 o'clock		N/A	N/A
1985-86 L4 - 2.0L (122 cu. in.) (Transverse)	3100062	3600006	42 MM	LF	4 o'clock		N/A	N/A
2004-2009 L4 - 2.0L (Transverse) [Optra]	see dealer	N/A	N/A	N/A	N/A		N/A	N/A
1987-2002 L4 - 2.0L, 2.2L (Transverse)	3100081	3600006	42 MM	LF	9 o'clock		N/A	N/A
2005-2008 L4 - 2.0L (Ecotec Supercharged) (Transverse)	3400020	3600082	CLAMP-ON	RR	N/A		N/A	N/A
2009-2010 L4 - 2.0L (Ecotec Turbo) (Transverse)	see dealer	N/A	N/A	N/A	N/A		N/A	N/A
2002-2004 L4 2.2L (Ecotec) (Transverse)	3400019	N/A	CLAMP-ON	RR	N/A		N/A	N/A
2005-2010 L4 2.2L (Ecotec) (Transverse)	3400020	3600082	CLAMP-ON	RR	N/A		N/A	N/A
1990-93 L4 - 2.3L QUAD IV	3100093	3600023	3/4" NPT	N/A	N/A		N/A	N/A
1994-95 L4 - 2.3L QUAD IV GEN II	3100001	3600002	1/2" NPT	N/A	N/A		N/A	N/A
1996-2002 L4 - 2.4L (Twin Cam)	3100001	3600002	1/2" NPT	N/A	N/A		N/A	N/A
2006-2011 L4 2.4L (Ecotec) (Transverse)	3400020	3600082	CLAMP-ON	RR	N/A		N/A	N/A
1980-92 L4 - 2.5L (Transverse)	3100076	3600006	1-5/8"	LF	12 o'clock		320-0003	750W
1977-86 L4 - 2.5L (Conventional)	3100076	3600006	1-5/8"	LR	6 or 12 o'clock		320-0003	750W
1962-70 L4 - 153 cu. in.	3100054	3600006	1-5/8"	LF	12 o'clock		320-0003	750W
6 Cylinder								
2004-2006 L6 - 2.5L (Transverse) [Epica]	see dealer	N/A	N/A	N/A	N/A		N/A	N/A
1980-88 V6 - 2.8L (Transverse) Except VIN W	3100014	3600006	34 MM	RS	3 o'clock		320-0003	N/A
1985-89 V6 - 2.8L (Transverse) VIN W	3100015	3600006	34 MM	CR or CF	3 o'clock		N/A	N/A
1982-89 V6 - 2.8L (Conventional)	3100014	3600006	34 MM	RFF IN BLOCK	3 o'clock		320-0003	750W
1990-96 V6 - 3.1, 3.4L (Conventional)	3100015	3600006	34 MM	RC	3 o'clock		N/A	N/A
1990-2003 V6 - 3.1L (Transverse)	3100015	3600006	34 MM	CR	3 o'clock		N/A	N/A
1992-97 V6 - 3.4L DOHC (Transverse)	3100015	3600006	34 MM	CR	3 o'clock		N/A	N/A
2000-2004 V6 - 3.4L (Transverse)	3100015	3600006	34 MM	CR	3 o'clock		N/A	N/A
2005-2009 V6 - 3.4L (Transverse) [Equinox]	3100109	3600082	28 MM THD	CR	N/A		N/A	N/A
2004 V6 - 3.5L (Transverse)	3100005	3600005	28 MM THD	CR	N/A		N/A	N/A
2005-2011 V6 - 3.5L (Transverse)	3100109	3600082	28 MM THD	CR	N/A		N/A	N/A
2008-2011 V6 - 3.6L (Transverse)	3100110	3600082	Cartridge	LR	N/A		N/A	N/A
2010-2011 V6 - 3.6L (Conventional)	3100110	3600082	Cartridge	RR	N/A		N/A	N/A
1980-84 V6 - 3.8L (229 cu. in.)	3100057	3600006	1-5/8"	LR	6 o'clock		320-0003	1000W
1978-88 V6 - 3.8L (231 cu. in.)	3100039	3600006	1-1/2"	RR	12 o'clock		320-0003	1000W
1998-2004 V6 - 3.8L (Transverse)	3100041	3600006	1-1/2"	RF or LF	12 o'clock		320-0003	N/A
2005-2011 V6 - 3.8L (Transverse)	3100109	3600082	28 MM THD	CR	N/A		N/A	N/A
1986-88 V6 - 3.8L (231 cu. in.) (Transverse)	3100041	3600006	1-1/2"	LF	3 o'clock		320-0003	N/A
1995-2002 V6 - 3.8L [Camaro]	3100041	3600006	1-1/2"	RR			N/A	N/A
2006-2011 V6 - 3.9L (Transverse)	3100109	3600006	28 MM THD	CR	N/A		N/A	N/A
1982-85 V6 - 4.3L (263 cu. in.) DIESEL (Conv)	3100039	3600006	1-1/2"	LR or RF	12 o'clock		N/A	1000W
1983-85 V6 - 4.3L (263 cu. in.) DIESEL (Transverse)	3100039	3600006	1-1/2"	RF or RR	12 o'clock		N/A	1000W
1985-88 V6 - 4.3L (263 cu. in.)	3100057	3600006	1-5/8"	LR	6 o'clock		320-0003	1000W
1955-73 L6 - ALL	3100054	3600006	1-5/8"	LF	12 o'clock		320-0004	1000W
1978-79 V6 - 200 cu. in.	3100057	3600006	1-5/8"	LR	9 o'clock		N/A	1000W
1974-79 L6 - 250 cu. in.	3100054	3600006	1-5/8"	LR	12 o'clock		320-0003	1000W
8 Cylinder								
1994-96 V8 - 4.3L	3100057	3600006	1-5/8"	LR	9 o'clock		N/A	N/A
1958-97 V8 - 5.0, 5.7L, 262, 267, 283, 305, 307, 327, 350, 400 (265 HP)	3100057	3600006	1-5/8"	LR	9 o'clock		320-0004	1500W
1986-90 V8 - 5.0L, 307 cu. in. VIN Y	3100039	3600006	1-1/2"	LF or RF	12 o'clock		320-0003	N/A
2006-2010 V8 - 5.3L (Transverse)	3100109	3600082	28 MM THD	RF	N/A		N/A	N/A
1980-85 V8 - 5.7L (350 cu. in.) DIESEL	3100039	3600006	1-1/2"	LF or RF	12 o'clock		N/A	750W
1998-2002 V8 - 5.7L (350 cu. in.) [Camaro]	3100005	3600005	28 MM THD	LR	N/A		N/A	N/A
1996-2004 V8 - 5.7L (350 cu. in.) [Corvette, inc Z06]	3100005	3600005	28 MM THD	LR	N/A		N/A	N/A

† Please confirm element orientation - improper position may result in heater or engine damage.

* Description of footnotes - see page 26. Circulation Heaters - see page 71. Lower Radiator Hose Heaters - see page 85.

MAKE, MODEL, YEAR & ENGINE	FREEZE PLUG HEATER (UNLESS OTHERWISE NOTED)						LOWER HOSE HEATER	CIRCULATION HEATER
	HEATER PART No.	REPL. CORD PART No.	BORE DIAMETER	INSTALLATION LOCATION	POINT ELEMENT†	NOTES*	PART No.	WATTAGE
CHEVROLET - continued								
2005-2007 V8 - 6.0L LS2 [C6 Corvette]	3100109	3600082	28 MM THD	LF	N/A		N/A	N/A
2008-2011 V8 - 6.2L LS3 [C6 Corvette, Camaro]	3100109	3600082	28 MM THD	LF	N/A		N/A	N/A
2008-2011 V8 - 6.2L LS9 [C6 Corvette ZR1]	3100109	3600082	28 MM THD	LF	N/A		N/A	N/A
2006-2011 V8 - 7.0L LS7 [C6 Corvette Z06]	3100109	3600082	28 MM THD	LF	N/A		N/A	N/A
1966-71 V8 - 396 cu. in.	3100065	3600006	1-3/4"	RC or RF	12 o'clock		320-0004	1500W
1970-77 V8 - 400 (300 HP), 402 cu. in.	3100065	3600006	1-3/4"	LF	3 o'clock		320-0003	1500W
1969 V8 - 427 cu. in.	3100065	3600006	1-3/4"	LF or RC	12 o'clock		320-0003	1500W
1970-77 V8 - 454 cu. in.	3100065	3600006	1-3/4"	RC	6 o'clock		320-0003	1500W
CHEVROLET & GMC (ALSO SEE GEO)								
LIGHT DUTY TRUCKS - includes vans/MPV								
4 Cylinder								
1988-95 L4 - 1.6 (Suzuki engine)	3400003	3600002	CLAMP-ON	N/A	N/A		310-0001	N/A
1977-82 L4 - 1.8L	3100018	3600006	35 MM	LF	12 o'clock		320-0002	N/A
1982-86 L4 - 1.9L (119 cu. in.)	3100018	3600006	35 MM	LF	12 o'clock		320-0002	N/A
1983-85 L4 - 2.0L (122 cu. in.)	3100014	3600006	34 MM	LF	12 o'clock		320-0002	750W
2009-2010 L4 - 2.0L (Ecotec Turbo) (Transverse)	see dealer	N/A	N/A	N/A	N/A		N/A	N/A
1994-2003 L4 - 2.2L	3100081	3600006	42 MM	LR	9 o'clock		N/A	N/A
1981-85 L4 - 2.2L DIESEL	3100068	3600006	1-3/4"	ANY LS	6 o'clock		N/A	750W
2006-2011 L4 2.4L (Ecotec) (Transverse)	3400020	3600082	CLAMP-ON	RR	N/A		N/A	
1985-94 L4 - 2.5L (151 cu. in.)	3100076	3600006	1-5/8"	LR	6 or 12 o'clock		320-0003	750W
1962-64 L4 - 153 cu. in.	3100054	3600006	1-5/8"	LF	12 o'clock		320-0003	750W
2004 L4 - 2.8L (Conventional)	3100005	3600005	28 MM THD	LC	N/A		N/A	N/A
2005-2006 L4 - 2.8L (Conventional)	3100109	3600082	28 MM THD	LC	N/A		N/A	N/A
2007-2009 L4 - 2.9L (Conventional)	3100109	3600082	28 MM THD	LC	N/A		N/A	N/A
2010-2011 L4 - 2.9L (Conventional)	see dealer	N/A	N/A	N/A	N/A		N/A	N/A
5 Cylinder								
2004 L5 - 3.5L (Conventional)	3100005	3600005	28 MM THD	LC	N/A		N/A	N/A
2005-2006 L5 - 3.5L (Conventional)	3100109	3600082	28 MM THD	LC	N/A		N/A	N/A
2007-2009 L5 - 3.7L (Conventional)	3100109	3600082	28 MM THD	LC	N/A		N/A	N/A
2010-2011 L5 - 3.7L (Conventional)	see dealer	N/A	N/A	N/A	N/A		N/A	N/A
6 Cylinder								
1984-95 Forward/Tiltmaster (W7H, W7I)	3100089	3600006	1" NPT	RS (2 required)	N/A		N/A	N/A
1987-95 Forward/Tiltmaster (W4, W5, W6, W7)	3100089	3600006	1" NPT	LS	N/A		N/A	N/A
1982-93 V6 - 2.8L (173 cu. in.)	3100014	3600006	34 MM	RFF IN BLOCK	3 o'clock		320-0003	750W
2010-2011 V6 - 2.8L Turbo	see dealer	N/A	N/A	N/A	N/A		N/A	N/A
2010-2011 V6 - 3.0L	see dealer	N/A	N/A	N/A	N/A		N/A	N/A
1990-96 V6 - 3.1L (Transverse)	3100015	3600006	34 MM	CR	3 o'clock		N/A	N/A
1990-2004 V6 - 3.4L (Transverse)	3100015	3600006	34 MM	CR	3 o'clock		N/A	N/A
2005-2009 V6 - 3.4L (Transverse)[Equinox]	3100109	3600082	28 MM THD	LC	N/A		N/A	N/A
1980-85 V6 - 3.8L (229 cu. in.) [El Camino]	3100057	3600006	1-5/8"	LR	9 o'clock		320-0003	1000W
1993-96 V6 - 3.8L (231 cu. in.) (Transverse)	3100041	3600006	1-1/2"	LF	3 o'clock		320-0003	N/A
1978-88 V6 - 3.8L (231 cu. in.) [El Camino]	3100039	3600006	1-1/2"	RR	12 o'clock		320-0003	1000W
2002-2004 L6 - 4.2L	3100005	3600005	28 MM THD	LF	N/A		N/A	N/A
2005-2007 L6 - 4.2L	3100109	3600082	28 MM THD	LF	N/A		N/A	N/A
1985-2005 V6 - 4.3L (263 cu. in.)	3100054	3600006	1-5/8"	LR	12 o'clock		320-0003	1000W
2006-2011 V6 - 4.3L	3100115	N/A	1-5/8"	LR	12 o'clock		320-0003	1000W
1974-89 L6 - 250, 292 cu. in.	3100054	3600006	1-5/8"	LR	12 o'clock		320-0003	1000W
1981-85 L6 - 4.1L (250 cu. in.)	3100054	3600006	1-5/8"	LR	12 o'clock		320-0003	1000W
1960-73 L6 - 194, 230, 248, 250, 261, 292 cu. in.	3100054	3600006	1-5/8"	LF	12 o'clock		320-0004	1000W
1960-74 V6 - 305, 351, 401, 478 cu. in.	3100065	3600006	1-3/4"	LF or RF	12 o'clock		N/A	1500W
8 Cylinder								
1955-72 V8 - 265,283,305,307,327,350,400 (265 HP)	3100057	3600006	1-5/8"	LR	9 o'clock		320-0004	1500W
1958-65 V8 - 348, 409 cu. in.	3100065	3600006	1-3/4"	LR	12 o'clock		320-0004	1500W
1972-89 V8 - 366, 396, 402, 427 cu. in.	3100065	3600006	1-3/4"	RC	12 o'clock		320-0004	1500W
1978-84 V8 - 5.7L (350 cu. in.) DIESEL	3100039	3600006	1-1/2"	LF or RF	12 o'clock		N/A	1500W
1981-00 V8 - 6.2, 6.5L DIESEL (600W heater)	3100057	3600006	1-5/8"	LC	6 or 12 o'clock		N/A	1500W
1981-00 V8 - 6.2, 6.5L DIESEL (1000W heater)	3100059	3600006	1-5/8"	LC	6 or 12 o'clock		N/A	1500W
2001-2006 V8 - 6.6L DIESEL (Duramax)	3100130	N/A	40MM	RF	12 o'clock		N/A	N/A
2007-2011 V8 - 6.6L DIESEL (Duramax)	3100130	3600006	40MM	RF	12 o'clock		N/A	N/A
1966-89 V8 - 7.4L (454 cu. in.)	3100065	3600006	1-3/4"	RC	6 o'clock		320-0004	1500W
1990-2004 V8 - 6.0, 5.7, 7.4L (366, 350, 454 cu. in.)	3100057	3600006	1-5/8"	LC or RC	6 o'clock		N/A	1500W
1973-2002 V8 - 5.0, 5.7, 6.6L (305, 350, 400 cu. in.)	3100057	3600006	1-5/8"	LR	9 o'clock		320-0003	1500W
1999-2004 V8 - 4.8, 5.3, 6.0, 8.1L (Gen 3)	3100005	3600005	28 MM THD	LR	N/A		N/A	N/A
2005-2011 V8 - 4.8, 5.3, 6.0, 6.2, 8.1L (Gen 3 & 4)	3100109	3600082	28 MM THD	LR or LF	N/A		N/A	N/A
1965-85 V8 - DH 637	3100065	3600006	1-3/4"	LF or RC	12 o'clock		320-0004	1500W

† Please confirm element orientation - improper position may result in heater or engine damage.

* Description of footnotes - see page 26. Circulation Heaters - see page 71. Lower Radiator Hose Heaters - see page 85.

MAKE, MODEL, YEAR & ENGINE	FREEZE PLUG HEATER (UNLESS OTHERWISE NOTED)					LOWER HOSE HEATER	CIRCULATION HEATER
	HEATER PART No.	REPL. CORD PART No.	BORE DIAMETER	INSTALLATION LOCATION	POINT ELEMENT†	NOTES*	PART No.
CHRYSLER							
AUTOMOTIVE							
4 Cylinder							
1979-84 L4 - 1.4L	3100016	3600006	35 MM	2ND LR	12 o'clock		N/A N/A
1985-96 L4 - 1.5L [G15B] (Transverse)	3100024	3600006	35 MM	LR or 2ND LR	9 o'clock		N/A N/A
1971-73 L4 - 1.5L (Conventional)	3100055	3600006	1-5/8"	2ND LS	12 o'clock		N/A N/A
1978-90 L4 - 1.6L (Transverse) [Colt/Champ]	3100016	3600006	35 MM	2ND LR	12 o'clock		N/A N/A
1989-90 L4 - 1.6L [4G61] DOHC TURBO	3100024	3600006	35 MM	2ND RR	4 o'clock	320-0003	N/A
1971-83 L4 - 1.6L (Conventional)	3100016	3600006	35 MM	LC	12 o'clock		N/A N/A
1978-83 L4 - 1.7L [Omni/Horizon]	3100034	3600016	36.5 MM	RR	6 o'clock		N/A N/A
1989-96 L4 - 1.8L (4G93)	3100020	3600006	35 MM	RF	3 o'clock		N/A N/A
2006-2011 L4 - 1.8L (Transverse) [Calibre]	3100111	3600083	cartridge	LF	N/A		N/A N/A
1974-82 L4 - 2.0L (Conventional)	3100049	3600006	40 MM	RF	6 o'clock		N/A N/A
1984-93 L4 - 2.0L [4G63] (Transverse)	3100024	3600006	35 MM	LR	3 o'clock		N/A N/A
1994-2005 L4 - 2.0L (Transverse) [Neon/Stratus]	3100024	3600006	35 MM	LR	3 o'clock		N/A N/A
2006-2007 L4 - 2.0L (Transverse) [Calibre]	3100111	3600083	cartridge	LF	N/A		N/A N/A
1992-2006 L4 - 2.4L [4G64] (Transverse)	3100075	3600004	35 MM	LR	3 o'clock		N/A N/A
2003-2007 L4 - 2.4L TURBO	3100075	3600004	35 MM	LR	3 o'clock		N/A N/A
2008-2009 L4 - 2.4L TURBO	3100111	3600083	cartridge	LF	N/A		N/A N/A
2006-2011 L4 - 2.4L (Transverse) [Calibre, Sebring]	3100111	3600083	cartridge	LF	N/A		N/A N/A
1981-97 L4 - 2.2L, 2.5L Including TURBO (600W)	3100055	3600006	1-5/8"	CR	6 or 12 o'clock		N/A N/A
1981-97 L4 - 2.2L, 2.5L Including TURBO (400W)	3100053	3600006	1-5/8"	CR	6 or 12 o'clock		N/A N/A
1981-89 L4 - 2.6L (Transverse)	3100049	3600006	40 MM	RR	9 o'clock		N/A 750W
1978-85 L4 - 2.6L (Conventional)	3100049	3600006	40 MM	RR	9 o'clock	320-0003	750W
1985-89 L4 - 2.6L (Conventional) TURBO	see dealer	N/A	N/A	N/A	N/A	320-0002	N/A
6 Cylinder							
1995-00 V6 - 2.5L [6G73] (Transverse)	3100055	3600006	1-5/8"	CR	3 o'clock		N/A N/A
2002-2009 V6 - 2.7L (Transverse)	see dealer	N/A	cartridge	LR	N/A		N/A N/A
1987-98 V6 - 3.0L [6G72] (Transverse)	3100055	3600006	1-5/8"	LR	12 o'clock		N/A N/A
2001-2005 V6 - 3.0L	3100055	3600006	1-5/8"	RR	12 o'clock		N/A N/A
1988-92 V6 - 3.0L [Monaco]	3100031	3600006	36 MM	RRF IN HEAD	9 o'clock		N/A N/A
2004-2008 V6 - 3.2L (Conventional) [Crossfire, SRT6]	3100105	N/A	38 MM THD	Lower Hose Fitting	N/A		N/A N/A
1990-98 V6 - 3.3L (Transverse)	3100055	3600006	1-5/8"	LR	12-1 o'clock		N/A N/A
1993-97 V6 - 3.3L (Conventional)	3100055	3600006	1-5/8"	RR	12-1 o'clock		N/A N/A
1993-97 V6 - 3.5L (Conventional)	3100055	3600006	1-5/8"	RR	12 o'clock		N/A N/A
1998-2011 V6 - 2.7, 3.2, 3.5L (Conventional)	see dealer	N/A	cartridge	RR	N/A		N/A N/A
2011 V6 - 3.6L Pentastar (Conventional)	see dealer	N/A	cartridge	RR	N/A		N/A N/A
2011 V6 - 3.6L Pentastar (Transverse)	see dealer	N/A	cartridge	LR	N/A		N/A N/A
1961-83 L6 - 170, 198, 225 cu. in. (Slant)	3100055	3600006	1-5/8"	LF	12 o'clock	320-0003	1000W
8 Cylinder							
1966-69 V8 - 273, 318, 340 cu. in.	3100055	3600006	1-5/8"	LC or RC	12 o'clock	320-0003	1500W
1966-69 V8 - 383, 400, 413, 426, 440 cu. in.	3100055	3600006	1-5/8"	LC or RC	12 o'clock	320-0004	1500W
1970-89 V8 - 318, 340, 360, 383, 400, 440 cu. in.	3100055	3600006	1-5/8"	LC or RC	12 o'clock	320-0004	1500W
2004- 2011 V8 - 5.7L HEMI	see dealer	N/A	cartridge	LR	N/A		N/A N/A
2005-2010 V8 - 6.1L HEMI	see dealer	N/A	cartridge	LR	N/A		N/A N/A
2011 V8 - 6.4L HEMI	see dealer	N/A	cartridge	LR	N/A		N/A N/A
10 Cylinder							
1996-2010 V10 - 8.0, 8.2, 8.3, 8.4L	see dealer	N/A	N/A	N/A	N/A		N/A N/A
DODGE LIGHT & MEDIUM DUTY TRUCKS & VANS							
4 Cylinder							
1992-96 L4 - 1.8L (4G93) [Vista/Summit]	3100020	3600006	35 MM	RF	3 o'clock		N/A N/A
1979-82 L4 - 2.0L	3100049	3600006	40 MM	RF	6 o'clock		N/A N/A
1983-89 L4 - 2.0L (4G63B) (122 cu. in.)	3100024	3600006	35 MM	RR	3 o'clock		N/A N/A
1984-91 L4 - 2.0L [Vista]	3100024	3600006	35 MM	2ND LR	9 o'clock		N/A N/A
1982-87 L4 - 2.2L (Transverse)	3100055	3600006	1-5/8"	CR	6 o'clock		N/A 750W
1982-87 L4 - 2.2L (Transverse)	3100053	3600006	1-5/8"	CR	6 o'clock		N/A 750W
1987-97 L4 - 2.2L, 2.5L (Conventional)	3100055	3600006	1-5/8"	RC	6 o'clock		N/A N/A
1983-85 L4 - 2.3L [4D55] (140 cu. in.) DIESEL	see dealer	3600006	40 MM	LR	9 o'clock		N/A N/A
1987-90 L4 - 2.4L [G64B] (Conventional)	3100024	3600006	35 MM	RR	3 o'clock		N/A N/A
1992-96 L4 - 2.4L [4G64] [Vista]	3100024	3600006	35 MM	LR/2ND LR	3 o'clock		N/A N/A
1986-95 L4 - 2.5L (Transverse)	3100055	3600006	1-5/8"	CR	6 o'clock		N/A N/A
1986-95 L4 - 2.5L (Transverse)	3100053	3600006	1-5/8"	CR	6 o'clock		N/A N/A
1986-90 L4 - 2.6L (Transverse)	3100049	3600006	40 MM	RR	9 o'clock	320-0002	N/A
1979-90 L4 - 2.6L (G54B) (Conventional)	see dealer	3600006	40 MM	RF	6 o'clock	320-0002	N/A
5 Cylinder							
2004-2006 L5 - 2.7L DIESEL	3100105	360-0084	38 MM THD	LF	N/A		N/A N/A

† Please confirm element orientation - improper position may result in heater or engine damage.

* Description of footnotes - see page 26. Circulation Heaters - see page 71. Lower Radiator Hose Heaters - see page 85.

MAKE, MODEL, YEAR & ENGINE	FREEZE PLUG HEATER (UNLESS OTHERWISE NOTED)						LOWER HOSE HEATER	CIRCULATION HEATER
	HEATER PART No.	REPL. CORD PART No.	BORE DIAMETER	INSTALLATION LOCATION	POINT ELEMENT*	NOTES*	PART No.	WATTAGE
DODGE LIGHT & MEDIUM DUTY TRUCKS & VANS - continued								
6 Cylinder								
1987-2007 V6 - 3.0, 3.3L, 3.8L (Transverse)	3100055	3600006	1-5/8"	LR	12 o'clock		N/A	N/A
1987-96 V6 - 3.0L [6G72] (Transverse)	3100055	3600006	1-5/8"	RR	9 o'clock		N/A	N/A
2007-2011 V6 - 3.0L DIESEL	see dealer	N/A	N/A	N/A	N/A		N/A	N/A
2002-2008 V6 - 3.7L	3100104	3600006	35 MM	2nd RR	N/A		N/A	N/A
1987-2003 V6 - 3.9L (239 cu. in.)	3100055	3600006	1-5/8"	RR	6 o'clock		N/A	100W
2007-2010 V6 - 4.0L	see dealer	N/A	N/A	N/A	N/A		N/A	
1960-88 L6 - 170, 198, 225 cu. in.	3100055	3600006	1-5/8"	LF	12 o'clock		320-0003	100W
1989-2001 L6 - 5.9L Cummins DIESEL	3500030	3600008	58 MM	RC	6 o'clock		N/A	N/A
2002-2006 L6 - 5.9L Cummins DIESEL	3500022	3600008	3/4 NPT	Rear of oil cooler	N/A		N/A	N/A
2007-2011 L6 - 6.7L Cummins DIESEL	3500022	3600008	3/4 NPT	Rear of oil cooler	N/A		N/A	N/A
8 Cylinder								
2000-2011 V8 - 4.7L	3100104		35 MM	RR	N/A		N/A	N/A
1962-96 V8 - ALL [Except Dakota]	3100055	3600006	1-5/8"	LC or RC	12 o'clock		320-0004	1500W
1991-99 V8 - 5.2L [Dakota]	3100055	3600006	1-5/8"	RR	6 o'clock		N/A	1500W
1996-2001 V8 - 5.2L [Ram] & [Durango]	3100055	3600006	1-5/8"	RR	6 o'clock		N/A	1500W
2003-2011 V8 - 5.7L HEMI	see dealer	N/A	cartridge	LR	N/A		N/A	N/A
1993-2002 V8 - 5.9L	3100055	3600006	1-5/8"	RR	6 o'clock		N/A	1500W
10 Cylinder								
1994-2008 V10 - 8.0L	3100091	3600006	1-5/8"	RR	11 o'clock		N/A	1500W
Note: Some Chrysler corp. engines have an .060 oversized frost plug hole. You may have to obtain an oversized o-ring 6027513 from a Chrysler dealer or from Temro 16874-32.								
DAEWOO								
4 Cylinder								
1999-2002 L4 - 1.6L [Lanos]	3100015	3600006	34 MM	LF	3 o'clock		N/A	N/A
1999-2002 L4 - 2.0L [Nubira]	3100015	3600006	34 MM	LF	3 o'clock		N/A	N/A
1999-2002 L4 - 2.2L [Leganza]	3100015	3600006	34 MM	LF	3 o'clock		N/A	N/A
EAGLE								
4 Cylinder								
1989-96 L4 - 1.5L (G15G) (Transverse)	3100024	3600006	35 MM	2ND LR	9 o'clock		N/A	N/A
1989-90 L4 - 1.6L (4G61) DOHC ENG	3100024	3600006	35 MM	2ND RR	4 o'clock		N/A	N/A
1992-96 L4 - 1.8L (4G93)	3100020	3600006	35 MM	RF	3 o'clock		320-0003	N/A
1990-96 L4 - 1.8L (4G37) [Talon]	3100024	3600006	35 MM	RF	12 o'clock		N/A	N/A
1989-98 L4 - 2.0L (4G63) TURBO [Talon]	see dealer	N/A	N/A	N/A	N/A		N/A	N/A
1995-97 L4 - 2.0L [Talon] (Chrysler engine)	3100024	3600006	35 MM	LR	3 o'clock		N/A	N/A
1988-89 L4 - 2.2L	3100003	3600001	1" NPT	RF	6 o'clock		N/A	N/A
1992-96 L4 - 2.4L (4G64) (Transverse) [Summit]	3100024	3600006	35 MM	LR/2ND LR	3 o'clock		N/A	N/A
1992-96 L4 - 2.4L (4G64) (Transverse)	3100024	3600006	35 MM	RF	3 o'clock		N/A	N/A
1988-89 L4 - 2.5L (150 cu. in.)	3100065	3600006	1-3/4"	LF	12 o'clock		N/A	N/A
6 Cylinder								
1988-93 V6 - 3.0L	3100031	3600006	36 MM	RRF IN HEAD	9 o'clock		N/A	N/A
1993-97 V6 - 3.3L (Conventional)	3100055	3600006	1-5/8"	LF	12-1 o'clock		N/A	N/A
1993-97 V6 - 3.5L (Conventional)	3100055	3600006	1-5/8"	RR	12 o'clock		N/A	N/A
FIAT								
2011 L4 - 1.4L	see dealer	N/A	N/A	N/A	N/A		N/A	N/A
FORD/MERCURY								
AUTOMOTIVE								
4 Cylinder								
1988-97 L4 - 1.3L	3100016	3600006	35 MM	2ND LR	12 o'clock		320-0001	N/A
1971-81 L4 - 1.3, 1.6L	3100057	3600006	1-5/8"	LF	12 o'clock		N/A	N/A
1971-73 L4 - 1.6L OHV	3100054	3600006	1-5/8"	LF	12 o'clock		N/A	N/A
1978-80 L4 - 1.6L (Transverse) [Fiesta]	3100053	3600006	1-5/8"	LF	9 o'clock		N/A	N/A
1981-85 L4 - 1.6L [Escort]	3100053	3600006	1-5/8"	LF	9 o'clock		N/A	N/A
1988-96 L4 - 1.6L [Tracer]	3100016	3600006	35 MM	2ND RF	12 o'clock		N/A	N/A
2010-11 L4 - 1.6L	see dealer	N/A	35 MM	RR	N/A		N/A	N/A
1991-96 L4 - 1.8L DOHC	3100021	3600006	35 MM	2ND RF	9 o'clock		N/A	N/A
1986-90 L4 - 1.9L (Transverse)	3100053	3600006	1-5/8"	LF	9 o'clock		N/A	N/A
1991-2004 L4 - 1.9L CVH, 2.0L SPI (Transverse)	3100102	3600006	35 MM	LR	9 o'clock		N/A	N/A
1971-75 L4 - 2.0L OHV/OHC	3100039	3600006	1-1/2"	RF	12 o'clock		N/A	N/A
1972-75 L4 - 2.0L OHV	3100039	3600006	1-1/2"	RF	12 o'clock		N/A	N/A
1984-88 L4 - 2.0L DIESEL	3100016	3600006	35 MM	2ND LF	12 o'clock		N/A	N/A
1993-97 L4 - 2.0L (Mazda engine)	3100023	3600006	35 MM	RR	8 o'clock		N/A	N/A
1995-2004 L4 - 2.0L (Zetec engine, inc SVT)*	3100018	3600006	35 MM	RR	3 o'clock		N/A	N/A
2004-2010 L4 - 2.0L (Duratec) (Transverse)	3100002	3600001	3/4" NPT	LR	N/A		N/A	N/A
2011 L4 - 2.0L (Focus)	see dealer	N/A	N/A	N/A	N/A		N/A	N/A

* Description of footnotes - see page 26. Circulation Heaters - see page 71. Lower Radiator Hose Heaters - see page 85.

* Mystique, Contour & Escort ZX2, Ford Focus **Mystique, Contour, Taurus, Sable, Probe

MAKE, MODEL, YEAR & ENGINE	FREEZE PLUG HEATER (UNLESS OTHERWISE NOTED)					LOWER HOSE HEATER	CIRCULATION HEATER
	HEATER PART No.	REPL. CORD PART No.	BORE DIAMETER	INSTALLATION LOCATION	POINT ELEMENT†	NOTES*	PART No.
FORD/MERCURY - continued							
2011 L4 2.0L EcoBoost	see dealer	N/A	N/A	N/A	N/A		N/A N/A
1989-92 L4 - 2.2L	3100016	3600006	35 MM	2ND RF	12 o'clock		N/A N/A
1989-92 L4 - 2.2L TURBO	3100017	3600006	35 MM	2ND RF	12 o'clock		N/A N/A
1974-95 L4 - 2.3L OHC (Conventional)	3100039	3600006	1-1/2"	RR or RF	6 or 12 o'clock		320-0002 N/A
2004-2011 L4 - 2.3L (Duratec) (Transverse)	3100002	3600001	3/4" NPT	LR	N/A		N/A N/A
1983-95 L4 - 2.3, 2.5L HSC (Transverse)	3100065	3600006	1-3/4"	LR & RR	6 o'clock		N/A N/A
6 Cylinder							
1993-97 V6 - 2.5L	3100028	3600006	35 MM	REAR	8 o'clock		N/A N/A
1995-2007 V6 - 2.5L, 3.0L 24-Valve (Duratec engine)**	3100002	3600001	3/4" NPT	RF	N/A		N/A N/A
2000-2005 V6 - 3.0L 24V (Conventional Duratec engine)**	3100002	3600001	3/4" NPT	RR	N/A		N/A N/A
1972-82 V6 - 2.6, 2.8L	3100036	3600003	1-1/2"	LFF or RFF	4 or 9 o'clock		N/A N/A
1987-90 V6 - 2.9L [Scorpio]	3100042	3600006	1-1/2"	LFF	10 o'clock		N/A N/A
1986-2006 V6 - 3.0L 12-VALVE (Transverse) [Except Villager and SHO]	3100039	3600006	1-1/2"	LF	6 o'clock		N/A N/A
1989-94 V6 - 3.0, 3.2L [SHO]	see dealer	N/A	N/A	N/A	N/A		N/A N/A
2007-2009 V6 - 3.5L (Transverse)	3100002	3600001	3/4" NPT	RR	N/A		N/A N/A
2009-2010 V6 - 3.5L GTDI EcoBoost	3100002	3600001	3/4" NPT	RR	N/A		N/A N/A
2009-2010 V6 - 3.7L (Transverse)	3100002	3600001	3/4" NPT	RR	N/A		N/A N/A
2010-2011 V6 - 3.7L (Conventional)	see dealer	N/A	cartridge	N/A	N/A		N/A N/A
1988-96 V6 - 3.8L (Transverse)	3100040	3600006	1-1/2"	LF	12 o'clock		320-0003 750W
1982-2004 V6 - 3.8L (Conventional)	3100040	3600006	1-1/2"	LR or RR	12 o'clock		320-0003 750W
2005-2009 V6 - 4.0L (conventional)	3100040	3600006	38MM	RR	7 o'clock		N/A N/A
1964-83 L6 - 170, 200, 250 cu. in.	3100065	3600006	1-3/4"	RC or RF	6 or 12 o'clock		320-0003 750W
1966-72 L6 - 240 cu. in.	3100054	3600006	1-5/8"	2ND RF	12 o'clock		N/A 750W
8 Cylinder							
1963-65 V8 - 221, 260, 289 cu. in.	3100039	3600006	1-1/2"	LR	12 o'clock		320-0003 1000W
1980-82 V8 - 255 cu. in. (4.2L)	3100039	3600006	1-1/2"	RR	6 o'clock		320-0003 1000W
1996-98 V8 - 3.4L [SHO]	3100002	3600001	3/4" NPT	NOT ACCESSIBLE	N/A		N/A N/A
2000-2005 V8 - 3.9L (conventional)	3100107	3600005	30 MM	LR	N/A		N/A N/A
1992-2010 V8 - 4.6L (Conventional)	3100040	3600006	1-1/2"	LR	9 o'clock		320-0003 1000W
1999-00 V8 - 4.6L (Conventional) [Mustang]	3100040	3600006	1-1/2"	RR	9 o'clock		N/A N/A
2001-2009 V8 - 4.6L (Conventional) [Mustang]	3100040	3600006	1-1/2"	LR	9 o'clock		N/A N/A
1995-2004 V8 - 4.6L 32V [Mustang]	3100040	3600006	1-1/2"	LR	9 o'clock		N/A N/A
2003-2004 V8 - 4.6L 32V [Merauder]	3100040	3600006	1-1/2"	LR	9 o'clock		N/A N/A
1995-2002 V8 - 4.6L (Transverse)	3100040	3600006	1-1/2"	LF	9 o'clock		N/A N/A
2011 V8 - 5.0L	3100002	3600001	3/4" NPT	LR	N/A		N/A N/A
2006-2011 V8 - 5.4L (Conventional) [Mustang]	3100040	3600006	1-1/2"	LR	9 o'clock		N/A N/A
1966-96 V8 - 289, 302 cu. in. (5.0L)	3100039	3600006	1-1/2"	LR or RR	6 o'clock		320-0003 1000W
1974-88 V8 - 351W, 351C, 351 cu. in. (5.8L)	3100039	3600006	1-1/2"	RR	12 o'clock		320-0003 1500W
1974-85 V8 - 351M, 400 cu. in.	3100039	3600006	1-1/2"	LR	9 o'clock		320-0003 750W
1968-78 V8 - 429, 460 cu. in.	3100039	3600006	1-1/2"	LF or RF	12 o'clock		320-0004 750W
1968-73 V8 - 351, 400, 429, 460 cu. in.	3100039	3600006	1-1/2"	LF or RF	12 o'clock		320-0003 750W
1963-71 V8 - 352, 390, 410, 427, 428 cu. in.	3100065	360-0006	1-3/4"	RF	6 or 12 o'clock		320-0003 750W
LIGHT & MEDIUM DUTY TRUCKS & VANS - INCLUDES AEROSTAR, EXPLORER & WINSTAR							
4 Cylinder							
1972-82 L4 - 1.8L	3100071	3600006	50 MM	LC	12 o'clock		N/A N/A
1983-88 L4 - 2.0L	3100039	3600006	1-1/2"	RR	6 o'clock		N/A N/A
1979-82 L4 - 1.8, 2.0L [Courier]	3100016	3600006	35 MM	LF	12 o'clock		N/A N/A
2002-2003 L4 - 2.0L (Zetec engine)*	3100018	3600006	35 MM	RR	3 o'clock		N/A N/A
2010-2011 L4 - 2.0L [Transit]	see dealer	N/A	N/A	N/A	N/A		N/A N/A
1981-85 L4 - 2.2L DIESEL	3100010	3600005	30 MM	RR	6 o'clock		N/A N/A
1977-94 L4 - 2.3L	3100039	3600006	1-1/2"	RR	6 o'clock		N/A N/A
1985-88 L4 - 2.3L Mitsubishi Diesel TURBO	see dealer	3600006	40 MM	LR	9 o'clock		N/A N/A
1995-97 L4 - 2.3L	3100084	3600006	1.5"	LR	3 o'clock		N/A N/A
2001-2007 L4 - 2.3L (Conventional)	3100002	3600001	3/4" NPT	RR	N/A		N/A N/A
2004-2011 L4 - 2.3L (Transverse)	3100002	3600001	3/4" NPT	LR	N/A		N/A N/A
1998-00 L4 2.5L	3100084	3600006	1.5"	LR	3 o'clock		N/A N/A
6 Cylinder							
1983-86 V6 - 2.8L	3100036	3600003	1-1/2"	RFF IN HEAD	10 o'clock		N/A N/A
1986-92 V6 - 2.9L	3100042	3600006	1-1/2"	LFF IN HEAD	10 o'clock		320-0003 N/A
1993-99 V6 - 3.0L (Transverse) [Villager]	3100009	3600004	30 MM	LF	6 o'clock		N/A N/A
1986-2003 V6 - 3.0L 12-Valve	3100039	3600006	1-1/2"	ANY	6 o'clock		N/A N/A
2001-2011 V6 - 3.0L 24-Valve (Duratec engine)**	3100002	3600001	3/4" NPT	RF	N/A		N/A N/A
1999-00 V6 - 3.3 (Transverse) [Villager]	3100009	3600004	30 MM	LF	6 o'clock		N/A N/A

† Please confirm element orientation - improper position may result in heater or engine damage.

* Description of footnotes - see page 26. Circulation Heaters - see page 71. Lower Radiator Hose Heaters - see page 85.

MAKE, MODEL, YEAR & ENGINE	FREEZE PLUG HEATER (UNLESS OTHERWISE NOTED)					LOWER HOSE HEATER	CIRCULATION HEATER
	HEATER PART No.	REPL. CORD PART No.	BORE DIAMETER	INSTALLATION LOCATION	POINT ELEMENT*	NOTES*	PART No.
FORD/MERCURY - continued							
2011 V6 - 3.5L (Conventional) [Ecoboost]	see dealer	N/A	Cartridge	N/A	N/A	N/A	N/A
2011 V6 - 3.7L (Conventional)	see dealer	N/A	Cartridge	N/A	N/A	N/A	N/A
1992-97 V6 - 3.8L CONV	3100039	3600006	1-1/2"	LR or RR	12 o'clock	N/A	N/A
1995-2003 V6 - 3.8L (Transverse)	3100040	3600006	1-1/2"	LF	6 o'clock	N/A	N/A
2004-2010 V6 - 3.9L (Transverse)	3100040	3600006	1-1/2"	LF	6 o'clock	N/A	N/A
1990-2010 V6 - 4.0L	3100039	3600006	1-1/2"	RF	6 o'clock	N/A	N/A
1996-2003 V6 - 4.2L (Conventional)	3100040	3600006	1-1/2"	LR	12 o'clock	N/A	N/A
2004-2008 V6 - 4.2L (Transverse)	3100040	3600006	1-1/2"	LF	6 o'clock	N/A	N/A
1964-74 L6 - 170, 200, 250 cu. in.	3100065	3600006	1-3/4"	RF	12 o'clock	320-0002	750W
1965-97 L6 - 3.9, 4.9L (240, 300 cu. in.)	3100054	3600006	1-5/8"	2ND RF	12 o'clock	320-0004	750W
1986-88 L6 - 6.6, 7.8L DIESEL							
(See Heavy Duty Application Guide)							
8 Cylinder							
1960-74 V8 - 292, 428 cu. in.	3100065	3600006	1-3/4"	LF or RF	12 o'clock	320-0004	1500W
1966-99 V8 - 5.0L (302 cu. in.), 289 cu. in.	3100039	3600006	1-1/2"	RR	6 o'clock	320-0004	1500W
1996-2010 V8 - 4.6L, 5.4L	3100040	3600006	1-1/2"	LR	12 o'clock	320-0004	1500W
2011 V8 - 5.0L	3100002	3600001	3/4" NPT	LR	N/A	N/A	
1966-97 V8 - 5.8L (351 cu. in.), 400 cu. in.	3100039	3600006	1-1/2"	LR or RR	12 o'clock	320-0004	1500W
1966-97 V8 - 7.5L (460 cu. in.), 429 cu. in.	3100039	3600006	1-1/2"	LF or RF	12 o'clock	320-0005	1500W
1960-80 V8 - 330, 352, 361, 389, 391 cu. in.	3100065	3600006	1-3/4"	RF or 2ND RF	12 o'clock	320-0005	1500W
1960-79 V8 - 360, 390 cu. in.	3100065	3600006	1-3/4"	LR or 2ND RF	12 o'clock	320-0005	1500W
1979-86 V8 - 370 cu. in.	3100039	3600006	1-1/2"	LR or RR	12 o'clock	320-0003	1500W
1960-81 V8 - 401, 475, 477, 534 cu. in.	3100065	3600006	1-3/4"	LR or 2ND RF	12 o'clock	N/A	1500W
2003-2006 V8 - 6.0L DIESEL (VT365)	3500069	3600008	27MM	RR	N/A	N/A	N/A
2011 V8 - 6.2L	3100002	3600001	3/4" NPT	LR	N/A	N/A	
2007-2010 V8 - 6.4L DIESEL	3500069	3600008	27MM	RR	N/A	N/A	N/A
2011 V8 - 6.7L DIESEL	3500069	3600008	27MM	LR	N/A	N/A	N/A
1983-94 V8 - 6.9, 7.3L DIESEL	3100043	3600010	1-1/2"	RR	11 o'clock	N/A	1500W
1995-2002 V8 - 7.3L (T444E)	3500043	3600008	3/4 NPT	oil filter	N/A	N/A	N/A
10 Cylinder							
1998-2010 V10 - 6.8L	3100040	3600006	1-1/2"	LR or RR	12 o'clock	320-0004	1500W
GEO							
3 Cylinder							
1989-97 L3 - 1.0L [Metro]	3400002	3600002	CLAMP-ON	N/A	N/A	N/A	N/A
4 Cylinder							
1989-99 L4 - 1.3L (Suzuki engine)	3400004	3600020	CLAMP-ON	N/A	N/A	N/A	N/A
1989 L4 - 1.5L	3100018	3600006	35 MM	CR	12 o'clock	N/A	N/A
1988-97 L4 - 1.6L (Suzuki engine) [Tracker]	3400003	3600002	CLAMP-ON	N/A	N/A	320-0001	N/A
1990-97 L4 - 1.6, 1.8L (Trans) (Suzuki engine) [Storm]	3100018	3600006	35 MM	2ND RR	12 o'clock	N/A	N/A
1985-97 L4 - 1.6, 1.8L (Trans) (Toyota engine) [Prizm]	3100049	3600006	40 MM	CF	12 o'clock	N/A	N/A
GMC - SEE CHEVROLET LIGHT & MEDIUM TRUCKS							
HINO - SEE HEAVY DUTY APPLICATION GUIDE							
HONDA							
AUTOMOTIVE							
4 Cylinder							
2002-2004 L4 - 1.0L	3100006	3600005	28 MM THD				
1973-83 L4 - 1.2, 1.3L	3400005	3600002	CLAMP-ON	N/A	N/A	N/A	N/A
1984-92 L4 - 1.3, 1.5L	3400001	3600002	CLAMP-ON	N/A	N/A	N/A	N/A
2003-2011 - 1.3L	3100006	3600005	28 MM THD				
1996-00 L4 - 1.6L (Transverse) 16-Valve	3100006	3600005	28 MM THD	LR	N/A	N/A	N/A
1999-00 L4 - 1.6L DOHC [Civic SiR]	3100006	3600005	28 MM THD	RF	N/A	N/A	N/A
1988-95 L4 - 1.5L, 1.6L (Transverse) 16-Valve only	3100006	3600005	28 MM THD	RF	N/A	N/A	N/A
1976-83 L4 - 1.5, 1.6L	3400006	3600002	CLAMP-ON	N/A	N/A	N/A	N/A
2006-2011 L4 - 1.5L [Fit]	see dealer	N/A	N/A	N/A	N/A	N/A	
2011 L4 - 1.5L [CRZ]	see dealer	N/A	N/A	N/A	N/A	N/A	
2001-2005 L4 - 1.7L (Transverse)	3100006	3600005	28 MM THD	LR	N/A	N/A	N/A
2006-2011 L4 - 1.8L (Transverse)	see dealer	N/A	N/A	N/A	N/A	N/A	N/A
1979-87 L4 - 1.6L, 1.8L, 2.0L (Transverse)	3100023	3600006	35 MM	RS	9 o'clock	N/A	N/A
1988-89 L4 - 2.0L (Transverse) [Accord]	3100023	3600006	35 MM	RS	9 o'clock	N/A	N/A
2002-2005 - L4 2.0L (Transverse) [Civic SiR]	3100006	3600005	28 MM THD	RR	N/A	N/A	N/A
2006-2011 L4 2.0L (Transverse) [Civic SiR]	3100006	3600005	28 MM THD	RR	N/A	N/A	N/A
1988-91 L4 - 2.0L, 2.1L (Transverse) [Prelude]	see dealer	N/A	CLAMP-ON	N/A	N/A	N/A	N/A
2000-2009 L4 - 2.0, 2.2L (conventional) [S2000]	3100006	3600005	28 MM THD	N/A	N/A	N/A	N/A
1990-97 L4 - 2.2L (Transverse) [Accord]	3100006	3600005	28 MM THD	LR	N/A	N/A	N/A
1992-2001 L4 - 2.2L, 2.3L (Transverse) [Prelude]	3100006	3600005	28 MM THD	RR	N/A	N/A	N/A

* Please confirm element orientation - improper position may result in heater or engine damage.

* Description of footnotes - see page 26. Circulation Heaters - see page 71. Lower Radiator Hose Heaters - see page 85.

MAKE, MODEL, YEAR & ENGINE	FREEZE PLUG HEATER (UNLESS OTHERWISE NOTED)					LOWER HOSE HEATER	CIRCULATION HEATER	
	HEATER PART No.	REPL. CORD PART No.	BORE DIAMETER	INSTALLATION LOCATION	POINT ELEMENT†	NOTES*	PART No.	WATTAGE
HONDA - continued								
1998-2002 L4 - 2.3L [Accord]	3100006	3600005	28 MM THD	LR	N/A		N/A	N/A
2003-2011 - 2.4L L4 [Accord]	3100006	3600005	28 MM THD	RR	N/A		N/A	N/A
6 Cylinder								
1998-2007 V6 - 3.0L [Accord]	3100006	3600005	28 MM THD	LF	N/A		N/A	N/A
2008-2011 V6 - 3.5L [Accord]	3100006	3600005	28 MM THD	LF	N/A		N/A	N/A
1995-97 V6 - 2.7L [Accord]	see dealer	N/A	N/A	CR	N/A		N/A	N/A
LIGHT TRUCK								
4 Cylinder								
1997-2001 L4 - 2.0L CRV	3100006	3600005	28 MM THD	RF	N/A		N/A	N/A
1995-98 -2.2L L4 ODYSSEY (Transverse)	3100006	3600005	28 MM THD	LR	N/A		N/A	N/A
2002-2011 - 2.4L L4 [CRV]	3100006	3600005	28 MM THD	RR	N/A		N/A	N/A
6 Cylinder								
1994-99 V6 - 3.2L [Passport]	3100005	3600005	28 MM THD	LR	N/A		N/A	N/A
1999-2010 V6 - 3.5L [Odyssey, Pilot, Ridgeline]	3100006	3600005	28 MM THD	LF	N/A		N/A	N/A
HUMMER								
5 Cylinder								
2005-2006 L5 - 3.5L [H3]	3100109	3600082	28 MM THD	LC	N/A		N/A	N/A
2007-2009 L5 - 3.7L [H3]	3100109	3600082	28 MM THD	LC	N/A		N/A	N/A
8 Cylinder								
2007-2009 V8 - 5.3L	3100109	3600082	28 MM THD	LR	N/A		N/A	N/A
2003-2004 V8 - 6.0L [H2]	3100005	3600005	28 MM THD	LR	N/A		N/A	N/A
2005-2009 V8 - 6.0L [H2]	3100109	3600082	28 MM THD	LR	N/A		N/A	N/A
HYUNDAI								
4 Cylinder								
1995-97 L4 - 1.5L [Accent]	3100098	3600006	35 MM	2ND LR	9 o'clock		N/A	N/A
1998-99 L4 - 1.5L [Accent]	3100098	3600006	35 MM	CR	4 o'clock		N/A	N/A
2000-2005 L4 - 1.5L [Accent]	3100098	3600006	35 MM	RF	9 o'clock		N/A	N/A
2006-2011 L4 - 1.6L [Accent]	3100114	3600006	35MM	LF	12 o'clock		N/A	N/A
1983-87 L4 - 1.4, 1.6L (Conventional)	3100098	3600006	35 MM	LC	12 o'clock		N/A	N/A
1986-95 L4 - 1.5L (Mitsubishi engine) [Excel]	3100098	3600006	35 MM	2ND LR	7 or 9 o'clock		N/A	N/A
1993-95 L4 - 1.5, 1.5L (Alpha engine) TURBO	3100098	3600006	35 MM	2ND LR	7 - 8 o'clock		N/A	N/A
1985-86 L4 - 1.6L	3100098	3600006	35 MM	LC	7 - 11 o'clock		N/A	N/A
2001-2005 L4 - 1.6L [Accent]	3100098	3600006	35 MM	2nd RR			N/A	N/A
1992-99 L4 - 1.6, 1.8L (Transverse)	3100098	3600006	35 MM	2ND RR	3 o'clock		N/A	N/A
1986-88 L4 - 2.0L (Conventional)	3100098	3600006	35 MM	2ND LF	9 o'clock		N/A	N/A
2009-2011 L4 - 2.0L Turbo (Conventional)	3100111	3600083	cartridge	RR	N/A		N/A	N/A
1989-2005 L4 - 2.0, 2.4L (Transverse)	3100098	3600006	35 MM	2ND RR	9 o'clock		N/A	N/A
1999 L4 - 2.4L (Transverse)	3100098	3600006	35 MM	LR	N/A		N/A	N/A
2006-2010 L4 - 2.4L (Transverse)	3100111	3600083	cartridge	LF	N/A		N/A	N/A
2010-2011 L4 - 2.4L (Transverse) (Theta 2)	See Dealer	N/A	Cartridge	RF	N/A		N/A	N/A
2011 L4 - 2.4L Turbo (Transverse) (Theta 2)	See Dealer	N/A	Cartridge	RF	N/A		N/A	N/A
6 Cylinder								
1989-98 V6 - 3.0L	3100055	3600006	1-5/8"	RF	12 o'clock		N/A	N/A
1999-2001 V6 - 2.5L	3100098	3600006	35 MM	LR	6 o'clock		N/A	N/A
2002-2005 V6 - 2.7L [Sonata, Tiburon]	3100098	3600006	35 MM	LR	6 o'clock		N/A	N/A
2001 V6 - 3.0L [XG300]	3100055	3600006	1-5/8"	LR	12 o'clock		N/A	N/A
2006-2011 V6 - 3.3L	3100113	3600083	25 MM THD	CR	N/A		N/A	N/A
2002-2005 V6 - 3.5L [XG350]	3100055	3600006	1-5/8"	LR	12 o'clock		N/A	N/A
2009-2011 V6 - 3.8L	See Dealer	N/A	Cartridge	RR	N/A		N/A	N/A
8 Cylinder								
2009-2011 V8 - 4.6L	See Dealer	N/A	Cartridge	RR	N/A		N/A	N/A
LIGHT TRUCK								
2001-2005 V6 - 2.7L	3100098	3600006	35 MM	LR	6 o'clock		N/A	N/A
2004-2005 V6 - 3.5L	3100055	3600006	1-5/8"	LR	12 o'clock		N/A	N/A
2006-2008 V6 - 3.8L	3100113	3600083	25 MM THD	CR	N/A		N/A	N/A
20010-2011 V6 - 3.5L (Transverse)	See Dealer	N/A	Cartridge	RR	N/A		N/A	N/A
2009-2011 V6 - 3.8L	See Dealer	N/A	Cartridge	RR	N/A		N/A	N/A
INFINITI								
4 Cylinder								
1991-2002 L4 - 2.0L	3100007	3600005	30 MM THD	LR	N/A		320-0003	N/A
6 Cylinder								
1998-2000 V6 - 3.3L (VG33)	3100009	3600004	30 MM	LR	6 o'clock		N/A	N/A
2001-2004 V6 - 3.5L	3100007	3600005	30 MM THD	LF	N/A		N/A	N/A
2005-2008 V6 - 4.0L (VQ40DE)	see dealer	N/A	N/A	N/A	N/A		N/A	N/A

† Please confirm element orientation - improper position may result in heater or engine damage.

* Description of footnotes - see page 26. Circulation Heaters - see page 71. Lower Radiator Hose Heaters - see page 85.

MAKE, MODEL, YEAR & ENGINE	FREEZE PLUG HEATER (UNLESS OTHERWISE NOTED)						LOWER HOSE HEATER	CIRCULATION HEATER
	HEATER PART No.	REPL. CORD PART No.	BORE DIAMETER	INSTALLATION LOCATION	POINT ELEMENT†	NOTES*	PART No.	WATTAGE
INFINITI - continued								
2004 V8 - 4.5L	3100007	3600005	30 MM THD	REAR	N/A		N/A	N/A
2004-2011 V8 - 5.6L (VK56DE)	3100007	3600005	30 MM THD	RF	N/A		N/A	N/A
8 Cylinder								
1990-96 V8 - 4.5L	3100007	3600005	30 MM THD	REAR	N/A		N/A	N/A
1997-00 V8 - 4.1L	3100007	3600005	30 MM THD	REAR	N/A		N/A	N/A
2001-2009 V8 - 4.5L	3100007	3600005	30 MM THD	REAR	N/A		N/A	N/A
LIGHT TRUCK								
6 Cylinder								
1998-2000 V6 - 3.3L (VG33)	3100009	3600004	30 MM	LR	6 o'clock		N/A	N/A
2001-2004 V6 - 3.5L	3100007	3600005	30 MM THD	LF	N/A		N/A	N/A
2005-2008 V6 - 4.0L (VQ40DE)	see dealer	N/A	N/A	N/A	N/A		N/A	N/A
2004 V8 - 4.5L	3100007	3600005	30 MM THD	REAR	N/A		N/A	N/A
2004-2011 V8 - 5.6L (VK56DE)	3100007	3600005	30 MM THD	RF	N/A		N/A	N/A
INTERNATIONAL BY NAVISTAR - LIGHT & MEDIUM DUTY TRUCKS (ALSO SEE HEAVY DUTY APPLICATION GUIDE)								
4 Cylinder								
ALL L4 - 152, 196 cu. in.	3100054	3600006	1-5/8"	RC or RF	12 o'clock		320-0005	750W
6 Cylinder								
ALL L6 - 225 cu. in.	3100054	3600006	1-5/8"	LF	12 o'clock		N/A	N/A
ALL L6 - 220, 240, 241, 264, 265 (Black Diamond)	3100054	3600006	1-5/8"	LF	12 o'clock		320-0005	750W
ALL L6 - 3.2L [SD-33] (Nissan DIESEL)	3100023	3600006	35 MM	2ND or 4TH LS	12 o'clock		N/A	N/A
8 Cylinder								
ALL V8 - 401, 461, 462, 478, 549, 550	3100038	3600006	1-1/2"	ANY LS or RS	12 o'clock		N/A	750W
ALL V8 - 401 cu. in. (AMC)	3100039	3600006	1-1/2"	RR	5 o'clock		N/A	750W
ALL V8 - 404, 446, 485, 537 cu. in., 9.0L	3100044	3600006	1-1/2"	ANY LS or RS	12 o'clock		N/A	1000W
ALL V8 to 93 - 6.9, 7.3L DIESEL	3100043	3600010	1-1/2"	RR	11 o'clock		N/A	1000W
94-2002 V8 - 7.3L (T444E)	3500043	3600008	3/4 NPT	oil cooler	N/A		N/A	N/A
ALL V8 - 266, 304, 345, 392, 400 cu. in.	3100054	3600006	1-5/8"	LF or RF	12 o'clock		N/A	750W
ISUZU								
AUTOMOTIVE - 4 Cylinder								
1992-93 L4 - 1.6, 1.8L	3100018	3600006	35 MM	2ND RR	12 o'clock		N/A	N/A
1985-89 L4 - 1.5L (Transverse)	3100018	3600006	35 MM	CR	12 o'clock		N/A	N/A
1981-88 L4 - 1.8L, 1.9L	3100018	3600006	35 MM	LF	12 o'clock		320-0002	N/A
1981-85 L4 - 1.8L DIESEL	3100018	3600006	35 MM	RR	12 o'clock		N/A	N/A
LIGHT & MEDIUM TRUCKS								
4 Cylinder								
1998-2002 L4 - 2.2L	3100081	3600006	42 MM	LR	9 o'clock		N/A	N/A
1985-95 L4 - 2.3L	3100019	3600006	35 MM	RF	3 o'clock		N/A	N/A
1982-89 L4 - 1.8L, 1.9L	3100018	3600006	35 MM	LF	12 o'clock		320-0002	750W
1982-86 L4 - 2.2L DIESEL	3100068	3600006	1-3/4"	LF	6 o'clock		N/A	750W
1988-95 L4 - 2.6L	3100098	3600006	35 MM	RF	6 o'clock		N/A	N/A
2007-2008 L4 - 2.9L (Conventional)	3100109	3600082	28 MM THD	LC	N/A		N/A	N/A
ALL L4 - 4BD1 engine	3100089	3600006	1" NPT	LR	N/A		320-0002	750W
5 Cylinder								
2007-2008 L5 - 3.7L (Conventional)	3100109	3600082	28 MM THD	LC	N/A		N/A	N/A
6 Cylinder								
1989-93 V6 - 2.8, 3.1L	3100014	3600006	34 MM	RFF IN BLOCK	3 o'clock		320-0002	750W
1992-2003 V6 - 3.2L	3100005	3600005	28 MM THD	LR	N/A		N/A	N/A
1998-99 V6 - 3.5L	3100005	3600005	28 MM THD	LR	N/A		N/A	N/A
2003-2005 L6 - 4.2L	3100005	3600005	28 MM THD	LF	N/A		N/A	N/A
2006-2007 L6 - 4.2L	3100109	3600082	28MM THD	LF	N/A		N/A	N/A
ALL L6 - 5.8L, 6.5L (6BD1,6BG1 engine)	3100089	3600006	1" NPT	LR	N/A		N/A	1500W
ALL L6 - 6SA1 Engine	3100089	3600006	1" NPT	RS	2 Required		N/A	1500W
8 Cylinder								
2003-2005 V8 - 5.3L	3100005	3600005	28 MM THD	LR	N/A		N/A	N/A
2006-2007 V8 - 5.3L	3100109	3600082	28 MM THD	LR	N/A		N/A	N/A
JAGUAR								
6 Cylinder								
1952-88 L6 - 2.5, 3.4, 3.6, 3.8, 4.2L	3100003	3600001	1" NPT	N/A	N/A		N/A	N/A
2000-2007 V6 - 3.0L	3100002	3600001	3/4" NPT	RR	N/A		N/A	N/A
2002-2008 V6 - 2.5, 3.0L (Transverse)	3100002	3600001	3/4" NPT	RF	N/A		N/A	N/A
8 Cylinder								
1998-2009 V8 - 4.0, 4.2L	see dealer	N/A	30 MM THD	LR	N/A		N/A	N/A
2010-2011 V8 - 5.0L	see dealer	N/A	30 MM THD	LR	N/A		N/A	N/A
12 Cylinder								
1971-97 V12 - 5.3, 6.0L	3100003	3600001	1" NPT	N/A	N/A		N/A	N/A

† Please confirm element orientation - improper position may result in heater or engine damage.

* Description of footnotes - see page 26. Circulation Heaters - see page 71. Lower Radiator Hose Heaters - see page 85.

MAKE, MODEL, YEAR & ENGINE	FREEZE PLUG HEATER (UNLESS OTHERWISE NOTED)					LOWER HOSE HEATER	CIRCULATION HEATER	
	HEATER PART No.	REPL. CORD PART No.	BORE DIAMETER	INSTALLATION LOCATION	POINT ELEMENT†	NOTES*	PART No.	WATTAGE
JEEP								
4 Cylinder								
1984-87 L4 - 2.1L DIESEL	3100003	3600001	1" NPT	RF	N/A		N/A	N/A
2002-2004 L4 2.4L	3100024	3600006	35 MM	RR/2ND RR	3 o'clock		N/A	N/A
2007-2011 L4 - 2.4L [Compass, Patriot]	3100111	3600083	Cartridge	LF	N/A		N/A	N/A
1980-83 L4 - 2.5L (Pontiac engine)	3100054	3600006	1-5/8"	LR	12 o'clock		N/A	750W
1984-2002 L4 - 2.5L	3100065	3600006	1-3/4"	LR	11 o'clock		N/A	750W
6 Cylinder								
1984-87 V6 - 2.8L (Chevrolet engine)	3100014	3600006	34 MM	RFF IN BLOCK	3 o'clock		3200003	750W
2007-2009 V6 - 3.0L DIESEL	see dealer	N/A	N/A	N/A	N/A		N/A	N/A
1963-71 L6 - 230 cu. in. (OHC)	3100057	360-0006	1-5/8"	ANY LS	6 o'clock		N/A	750W
2002-2011 V6 - 3.7L	3100104	3600006	35mm	2nd RR	N/A		N/A	N/A
1965-71 L6 - 225 cu. in.	3100039	3600006	1-1/2"	LR	2 o'clock		N/A	N/A
2011 V6 - 3.6L Pentastar	see dealer	N/A	N/A	RR	N/A		N/A	N/A
2007-2010 V6 - 3.8L	see dealer	N/A	N/A	N/A	N/A		N/A	N/A
1987-2006 L6 - 4.0L	3100072	3600006	2"	LF	12 o'clock		3200003	N/A
1968-90 L6 - 4.2L	3100072	3600006	2"	LR	12 o'clock		3200003	N/A
8 Cylinder								
1968-71 V8 - 350 cu. in. (Buick engine)	3100039	3600006	1-1/2"	LF or RR	12 o'clock		N/A	750W
1972-91 V8 - 304, 360, 401 cu. in.	3100039	3600006	1-1/2"	LR	5 o'clock		3200003	750W
1999-2007 V8 4.7L	3100104	3600006	35mm	RR	N/A		N/A	N/A
1993-98 V8 - 5.2L	3100055	3600006	1-5/8"	RR	6 o'clock		N/A	750W
2005-2011 V8 - 5.7L HEMI	see dealer	N/A	cartridge	LR	N/A		N/A	N/A
1998 V8 - 5.9L	3100055	3600006	1-5/8"	RR	6 o'clock		N/A	1500W
2006-2010 V8 - 6.1L HEMI	see dealer	N/A	cartridge	LR	N/A		N/A	N/A
KIA								
4 Cylinder								
2001-2002 L4 1.5L [Rio]	See Dealer	3600006	35MM	N/A	N/A		N/A	N/A
2003-2004 L4 1.6L [Rio]	See Dealer	3600006	35MM	N/A	N/A		N/A	N/A
2006-2010 L4 1.6L [Rio]	3100114	3600006	35MM	LF	12 o'clock		N/A	N/A
2009-2011 L4 1.6L [Soul]	See Dealer	N/A	Cartridge	RR	N/A		N/A	N/A
1998-2003 L4 - 1.8L [Sephia, Spectra]	3100016	3600006	35 MM	RF	12 o'clock		N/A	N/A
1995-2003 L4 - 2.0L [Sportage]	3100016	3600006	35 MM	2nd LF	12 o'clock		N/A	N/A
2004-2006 L4 - 2.0L [Spectra, Sportage]	3100098	3600006	35 MM	2nd RR	9 o'clock		N/A	N/A
2009-2011 L4 2.0L [Forte]	3100111	3600083	cartridge	LF	N/A		N/A	N/A
2002-2006 L4 - 2.4L (Transverse)	3100098	3600006	35 MM	LR	6 o'clock		N/A	N/A
2006-2011 L4 - 2.4L (Transverse) [Optima, Magentis, Forte]	3100111	3600083	cartridge	LF	N/A		N/A	N/A
6 Cylinder								
2001 V6 - 2.5L [Magentis]	3100098	3600006	35 MM	LR	6 o'clock		N/A	N/A
2002-2005 V6 - 2.7L [Magentis, Sportage]	3100098	3600006	35 MM	LR	6 o'clock		N/A	N/A
2007-2009 V6 - 3.3L [Sorento]	3100113	3600083	25 MM THD	RR	N/A		N/A	N/A
2002-2005 V6 - 3.5L [Sedona]	3100055	3600006	1-5/8"	LR	12 o'clock		N/A	N/A
2004-2006 V6 - 3.5L [Amanti]	3100055	3600006	1-5/8"	LR	12 o'clock		N/A	N/A
2003-2005 V6 - 3.5L [Sorento]	3100055	3600006	1 5/8"	RR	12 o'clock		N/A	N/A
2010-2011 V6 - 3.5L [Sorento]	See Dealer	N/A	Cartridge	LR	N/A		N/A	N/A
2006-2009 V6 - 3.8L [Sedona]	3100113	3600083	25 MM THD	CR	N/A		N/A	N/A
2007-2009 V6 - 3.8L [Amanti]	3100113	3600083	25 MM THD	CR	N/A		N/A	N/A
2009-2011 V6 - 3.8L [Borrego]	See Dealer	N/A	Cartridge	RR	N/A		N/A	N/A
2010-2011 V6 - 3.8L [Sedona]	3100111	3600083	cartridge	LR	N/A		N/A	N/A
8 Cylinder								
2009-2011 V8 - 4.6L [Borrego]	3100113	3600083	25 MM THD	LR	N/A		N/A	N/A
LADA								
1978-93 L4 - 1.5L	3100050	3600006	40 MM	LF	9 o'clock		N/A	N/A
1981-93 L4 - 1.6L	3100050	3600006	40 MM	LS	9 o'clock		N/A	N/A
1987-93 L4 - 1.3, 1.5L (Transverse)	3100032	3600006	36 MM	LF	3 o'clock		N/A	N/A
LEXUS								
6 Cylinder								
2001-2005 L6 L6 - 3.0L	see dealer	N/A	N/A	N/A	N/A		N/A	N/A
1989-91 V6 - 2.5L	3100019	3600006	35 MM	CF	6 o'clock		N/A	N/A
2006-2011 V6 - 2.5L (4GR-FSE)(Conventional)	see dealer	N/A	N/A	LR	N/A		N/A	N/A
1992-94 V6 - 3.0L (3VZ-FE)	3100021	3600006	35 MM	LF	3 o'clock		N/A	N/A
1994-2003 V6 - 3.0L (1MV-FE)	3100029	3600006	35 MM	RF	3 o'clock		N/A	N/A
1992-96 L6 - 3.0L (Conventional)	see dealer	N/A	N/A	N/A	N/A		N/A	N/A
2004-2006 V6 - 3.3L (3MZ-FE)	3100029	3600006	35 MM	RF	3 o'clock		N/A	N/A
2007-2011 V6 - 3.5L (2GR-FE)(Transverse)	see dealer	N/A	N/A	N/A	N/A		N/A	N/A
2006-2011 V6 - 3.5L (2GR-FSE)(Conventional)	see dealer	N/A	N/A	LR	N/A		N/A	N/A

† Please confirm element orientation - improper position may result in heater or engine damage.

* Description of footnotes - see page 26. Circulation Heaters - see page 71. Lower Radiator Hose Heaters - see page 85.

MAKE, MODEL, YEAR & ENGINE	FREEZE PLUG HEATER (UNLESS OTHERWISE NOTED)						LOWER HOSE HEATER	CIRCULATION HEATER
	HEATER PART No.	REPL. CORD PART No.	BORE DIAMETER	INSTALLATION LOCATION	POINT ELEMENT†	NOTES*	PART No.	WATTAGE

LEXUS - continued								
8 Cylinder								
1989-2001 V8 - 4.0L	see dealer	N/A	N/A	N/A	N/A		N/A	N/A
2002-2007 V8 - 4.3L (3UZ-FE)	3100029	3600006	35 MM	RF	ANY		N/A	N/A
2007-2011 V8 - 4.6L (1URFS, 1UR-FSE, 2UR-FSX)	see dealer	N/A	N/A	N/A	N/A		N/A	N/A
2008-2011 V8 - 5.0L (2UR-FSE)	see dealer	N/A	N/A	N/A	N/A		N/A	N/A
2008-2011 V8 - 5.0L (2UR-GSE) [IS-F]	see dealer	N/A	N/A	N/A	N/A		N/A	N/A

LIGHT TRUCKS								
6 Cylinder								
1999-2003 V6 - 3.0L	3100029	3600006	35 MM	RF	3 o'clock		N/A	N/A
2004-2006 V6 - 3.3L (3MZ-FE)	3100029	3600006	35 MM	RF	3 o'clock		N/A	N/A
2007-2010 V6 - 3.5L (2GR-FE)(Transverse)	see dealer	N/A	N/A	LF	N/A		N/A	

8 Cylinder								
2010-2011 V8 - 4.6L	see dealer	N/A	35 MM	RF	N/A		N/A	N/A
1998-2009 V8 4.7L (2UZ-FE)	see dealer	N/A	35 MM	RF	N/A		N/A	N/A
2008-2011 V8 - 5.7L (2UR-FE)	3100129	3600083	Cartridge	LR	N/A		N/A	N/A
10 Cylinder								
2010-2011 V10 4.8L	see dealer	N/A	N/A	N/A	N/A		N/A	N/A

MAZDA
AUTOMOTIVE

Rotary								
1971-96 R2 - ALL	3400007	3600002	CLAMP-ON	N/A	N/A		N/A	N/A
2004-2011 R2 [RX8]	see dealer	N/A	N/A	N/A	N/A		N/A	N/A

4 Cylinder								
1971-80 L4 - 1.2L (Conventional)	3400008	3600001	CLAMP-ON	N/A	N/A		N/A	N/A
1975-80 L4 - 1.3L, 1.4L, 1.5L (Conventional)	3100016	3600006	35 MM	LF	6 o'clock		N/A	N/A
1981-82 L4 - 1.5L	3400009	3600002	CLAMP-ON	N/A	N/A		N/A	N/A
1981-85 L4 - 1.5L (Transverse)	3100019	3600006	35 MM	LF	3 o'clock		N/A	N/A
1995-98 L4 - 1.5L	3100023	3600006	35 MM	2ND RF	6 or 12 o'clock		N/A	N/A
1986-89 L4 - 1.6L (Transverse) (Except TURBO)	3100016	3600006	35 MM	2ND RF	12 o'clock		N/A	N/A
1988-89 L4 - 1.6L (Transverse) DOHC TURBO	3100017	3600006	35 MM	2ND RF	12 o'clock		N/A	N/A
1990-98 L4 - 1.6L (Transverse)	3100023	3600006	35 MM	2ND RF	9 o'clock		N/A	N/A
1989-95 L4 - 1.6L DOHC (Conventional)	3100016	3600006	35 MM	2ND LF	12 o'clock		N/A	N/A
1970-80 L4 - 1.6L, 1.8L (Conventional)	3100071	3600006	50 MM	LC	12 o'clock		N/A	N/A
1999 L4 1.6L L4 DOHC (Transverse)	see dealer	N/A	N/A	N/A	N/A		N/A	N/A
2010-2011 L4 1.6L (Transverse) [Mazda 2]	see dealer	N/A	35MM	LR	N/A		N/A	N/A
1990-98 L4 - 1.8L SOHC	3100021	3600006	35 MM	2ND RF	6 o'clock		N/A	N/A
1995-99 L4 - 1.8L DOHC	3100016	3600006	35 MM	2ND RF	12 o'clock		N/A	N/A
1999-00 L4 1.8L DOHC (Transverse)	see dealer	N/A	N/A	N/A	N/A		N/A	N/A
1985-87 L4 - 2.0L DIESEL	3100016	360 0006	35 MM	2ND RF	12 o'clock		N/A	N/A
1983-92 L4 - 2.0L [626] (Transverse)	3100016	360 0006	35 MM	2ND RF	9 o'clock		N/A	N/A
1979-82 L4 - 2.0L (Conventional)	3100071	360 0006	50 MM	LC	12 o'clock		N/A	N/A
1993-98 L4 - 2.0L	3100023	360 0006	35 MM	RR	8 o'clock		N/A	N/A
1998-2003 L4 - 2.0L DOHC [626, Ptotege]	see dealer	N/A	35MM	RR	N/A		N/A	N/A
2003-2004 L4 - 2.0L DOHC Turbo	see dealer	N/A	35MM	RR	N/A		N/A	N/A
2004-2011 L4 - 2.0L [Mazda 3]	3100002	360 0001	3/4" NPT	LR	N/A		N/A	N/A
2006-2007 L4 - 2.0L [Mazda MX5]	3100002	360 0001	3/4" NPT	RR	N/A		N/A	N/A
1988-92 L4 - 2.2L [626] (Transverse)	3100016	360 0006	35 MM	2ND RF	12 o'clock		N/A	N/A
1988-92 L4 - 2.2L TURBO	3100017	360 0006	35 MM	2ND RF	12 o'clock		N/A	N/A
2003-2009 L4 - 2.3L [Mazda 3, Mazda 5, Mazda 6]	3100002	360 0001	3/4" NPT	LR	N/A		N/A	N/A
2006-2011 L4 - 2.3L Turbo	3100002	360 0001	3/4" NPT	LR	N/A		N/A	N/A
2009-2011 L4 2.5L [Mazda 3, Mazda 6]	3100002	360 0001	3/4" NPT	LR	N/A		N/A	N/A

6 Cylinder								
1992-99 V6 - 1.8L, 2.5L (Transverse)	3100028	360 0006	35 MM	REAR	8 o'clock		N/A	N/A
1995-2002 V6 - 2.5L, 2.3L (Miller cycle engine)	3100028	360 0006	35 MM	REAR	1 o'clock		N/A	N/A
1988-97 V6 - 3.0L	3100016	360 0006	35 MM	RF	6 o'clock		N/A	N/A
2003-2008 V6 - 3.0L [Mazda 6]	3100002	360 0001	3/4" NPT	RF	N/A		N/A	N/A
2009-2011 V6 - 3.7L [Mazda 6]	3100002	360 0001	3/4" NPT	RR	N/A		N/A	N/A

LIGHT & MEDIUM DUTY TRUCKS								
4 Cylinder								
1971-77 L4 - 1.6L	3100071	360 0006	50 MM	LC	6 o'clock		N/A	N/A
1977-84 L4 - 1.8L, 2.0L	3100071	360 0006	50 MM	LC	12 o'clock		N/A	N/A
1985-93 L4 - 2.0L, 2.2L GAS	3100016	360 0006	35 MM	2ND LF	12 o'clock		N/A	N/A
2001-2003 L4 - 2.0L [Tribute] (Ford engine)	3100018	360 0006	35 MM	RR	3 o'clock		N/A	N/A
1982-87 L4 - 2.2L DIESEL	3100023	360 0006	35 MM	2ND RF	3 or 9 o'clock		N/A	N/A
2001-2011 L4 - 2.3L [B2300]	3100002	360 0001	3/4" NPT	RR	N/A		N/A	N/A

† Please confirm element orientation - improper position may result in heater or engine damage.

* Description of footnotes - see page 26. Circulation Heaters - see page 71. Lower Radiator Hose Heaters - see page 85.

MAKE, MODEL, YEAR & ENGINE	FREEZE PLUG HEATER (UNLESS OTHERWISE NOTED)						LOWER HOSE HEATER	CIRCULATION HEATER
	HEATER PART No.	REPL. CORD PART No.	BORE DIAMETER	INSTALLATION LOCATION	POINT ELEMENT†	NOTES*	PART No.	WATTAGE
MAZDA - continued								
1994 L4 - 2.3L [B2300] (Ford engine)	3100039	360 0006	1-1/2"	RR	12 o'clock		N/A	N/A
1995-97 L4 - 2.3L [B2300] (Ford engine)	3100084	360 0006	1-1/2"	LR	3 o'clock		N/A	N/A
2004-2008 L4 - 2.3L [Tribute]	3100002	360 0001	3/4" NPT	LR	N/A		N/A	N/A
2006-2011 L4 - 2.3L Turbo [CX-7]	3100002	360 0001	3/4" NPT	LR	N/A		N/A	N/A
1998-00 L4 - 2.5L (Ford engine)	3100084	360 0006	1.5 IN	LR	3 o'clock		N/A	N/A
2009-2011 L4 - 2.5L [Tribute]	3100002	360 0001	3/4" NPT	LR	N/A		N/A	N/A
1989-95 L4 - 2.6L [B2600] & MPV (Mazda engine)	3100075	360 0006	35 MM	2ND LF	9 o'clock		N/A	N/A
1987-88 L4 - 2.6L [B2600] (Mitsubishi engine)	3100049	360 0006	40 MM	RF	6 o'clock		N/A	N/A
6 Cylinder								
2000-2001 V6 - 2.5L [MPV] (Ford engine)	3100002	360 0001	3/4" NPT	RF	N/A		N/A	N/A
1989-93 V6 - 3.0L	3100016	360 0006	35 MM	RF	6 o'clock		N/A	N/A
2001-2011 V6 - 3.0L [Tribute] (Ford engine)	3100002	360 0001	3/4" NPT	RF	N/A		N/A	N/A
2002-2011 V6 - 3.0L [MPV] (Ford engine)	3100002	360 0001	3/4" NPT	RF	N/A		N/A	N/A
1994-2011 V6 - 3.0L [B3000] (Ford engine)	3100039	360 0006	1-1/2"	RR	12 o'clock		N/A	N/A
2007-2008 V6 - 3.5L [CX-9]	3100002	360 0001	3/4" NPT	RR	N/A		N/A	N/A
2008-2011 V6 - 3.7L (Transverse)	3100002	360 0001	3/4" NPT	RR	N/A		N/A	N/A
1991-2011 V6 - 4.0L [B4000] (Ford engine)	3100039	360 0006	1-1/2"	RF	6 o'clock		N/A	N/A
MERCEDES-BENZ								
4 Cylinder								
ALL 230	3100105	N/A	38 MM THD	SEE INSTRUCTIONS	N/A		N/A	1000W
ALL DIESEL-Except 190D (1984 & newer)	3100105	N/A	38 MM THD	SEE INSTRUCTIONS	N/A		N/A	N/A
1994-2004 L4 - 1.8L, 2.0L, 2.3L (M111)	3100105	N/A	38 MM THD	SEE INSTRUCTIONS	N/A		N/A	N/A
2001-2007 L4 - 1.8L (M271)	8604967	N/A	3/4" NPT	RF	N/A		N/A	N/A
2006-2011 L4 - 2.0L [B Class]	see dealer	N/A	N/A	N/A	N/A		N/A	N/A
5 Cylinder								
ALL DIESEL	3100105	N/A	38 MM THD	SEE INSTRUCTIONS	N/A		N/A	N/A
6 Cylinder								
1998-2005 V6 - 2.6L, 3.2L, 3.7L (M112)	3100105	N/A	38 MM THD	Lower hose casting	N/A		N/A	N/A
2004-2011 V6 - 2.5L, 3.0L, 3.5L (M272)	3100105	N/A	38 MM THD	Lower hose casting	N/A		N/A	N/A
2007-2011 V6 - 3.2L DIESEL	3100105	N/A	38 MM THD	Lower hose casting	N/A		N/A	N/A
8 Cylinder								
ALL V8 1971-2000	3100105	N/A	38 MM THD	SEE INSTRUCTIONS	N/A		N/A	N/A
2001-2007 V8 - 4.3L, 5.0L, 5.4L (M113)	3100105	N/A	38 MM THD	Lower hose casting	N/A		N/A	N/A
2006-2009 V8 - 4.7L, 5.0L (M273)	3100105	N/A	38 MM THD	Lower hose casting	N/A		N/A	N/A
2011 V8 - 4.7L Turbo	see dealer	N/A	N/A	N/A	N/A		N/A	N/A
2004-2009 V8 - 5.4L (M155) [SLR McLaren]	see dealer	N/A	N/A	N/A	N/A		N/A	N/A
2011 V8 5.5L Turbo	see dealer	N/A	N/A	N/A	N/A		N/A	N/A
2006-2011 V8 - 6.2L AMG (M156)	see dealer	N/A	N/A	N/A	N/A		N/A	N/A
12 Cylinder								
2001-2005 V12 - 5.8L (M137)	3100105	N/A	38 MM THD	Lower hose casting	N/A		N/A	N/A
2002-2011 V12 - 5.5L, 6.0L Turbo (M275/285)	3100105	N/A	38 MM THD	Lower hose casting	N/A		N/A	N/A
1989-2008 V12 - 7.3L AMG (M120)	see dealer	N/A	N/A	N/A	N/A		N/A	N/A
MINI								
4 Cylinder								
2003-2006 L4 1.6L	see dealer	N/A	N/A	N/A	N/A		N/A	N/A
2007-2011 L4 - 1.6L	see dealer	N/A	N/A	N/A	N/A		N/A	N/A
MITSUBISHI								
AUTOMOTIVE								
4 Cylinder								
1985-93 L4 - 1.5L [Precis]	3100024	3600006	35 MM	2ND LR	9 o'clock		N/A	N/A
1987-2001 L4 - 1.5L (G15B) [Mirage]	3100024	3600006	35 MM	2ND LR	9 o'clock		N/A	N/A
1989-92 L4 - 1.6L (4G61)	3100024	3600006	35 MM	2ND RR	4 o'clock		N/A	N/A
1993-99 L4 - 1.8L (4G93) [Expo/Mirage]	3100024	3600006	35 MM	RF	3 o'clock		N/A	N/A
1989-94 L4 - 1.8L (4G37) [Eclipse]	3100024	3600006	35 MM	RF	12 o'clock		3200003	N/A
1989-96 L4 - 2.0L (4G63) [Eclipse]	see dealer	N/A	N/A	N/A	N/A		N/A	N/A
1989-93 L4 - 2.0L (4G63) [Galant]	3100024	3600006	35 MM	LR	3 o'clock		N/A	N/A
1995-99 L4 - 2.0L (420A) [Eclipse non-turbo]	3100024	3600006	35 MM	2ND LR	9 o'clock		N/A	N/A
2004-2006 L4 - 2.0L [Lancer]	3100075	3600006	35 MM	2ND LF	3 o'clock		N/A	N/A
2004-2006 L4 - 2.0L [Lancer Evo VIII]	see dealer	N/A	N/A	N/A	N/A		N/A	N/A
2007-2010 L4 - 2.0L [Lancer]	3100111	3600083	Cartridge	LF	N/A		N/A	N/A
2008-2010 L4 - 2.0L Turbo [Lancer Evo]	3100111	3600083	Cartridge	LF	N/A		N/A	N/A
1982-96 L4 - 2.4L (4G64) [Expo/Expo LRV]	3100024	3600006	35 MM	LR/2ND LR	3 o'clock		N/A	N/A
1992 L4 - 2.4L (4G64) [Galant DOHC]	3100024	3600006	35 MM	RF	3 o'clock		N/A	N/A
1994-98 L4 - 2.4L (4G64) [Galant SOHC]	3100024	3600006	35 MM	RF	3 o'clock		N/A	N/A

† Please confirm element orientation - improper position may result in heater or engine damage.

* Description of footnotes - see page 26. Circulation Heaters - see page 71. Lower Radiator Hose Heaters - see page 85.

MAKE, MODEL, YEAR & ENGINE	FREEZE PLUG HEATER (UNLESS OTHERWISE NOTED)						LOWER HOSE HEATER	CIRCULATION HEATER
	HEATER PART No.	REPL. CORD PART No.	BORE DIAMETER	INSTALLATION LOCATION	POINT ELEMENT*	NOTES*	PART No.	WATTAGE
MITSUBISHI - continued								
1999-2008 L4 - 2.4L (4G64) [Galant, 00 Eclipse]	3100020	3600006	35 MM	2ND LF	4 o'clock		N/A	N/A
1996-99 L4 - 2.4L (4G64) [Eclipse Spyder]	3100024	3600006	35 MM	RF	3 o'clock		N/A	N/A
2004-2007 L4 - 2.4L (JT41/45 4 MIVEC) [Galant, Lancer]	3100075	3600006	35 MM	LF	3 o'clock		N/A	N/A
2008-2011 L4 - 2.4L [Lancer GTS]	3100111	3600083	Cartridge	LF	N/A		N/A	N/A
6 Cylinder								
1995-96 V6 - 2.5L (6G73) [Galant]	3100055	3600006	1-5/8"	CR	3 o'clock		N/A	N/A
1988-96 V6 - 3.0L (6G72) [Except 3000GT]	3100055	3600006	1-5/8"	RF	9 o'clock		N/A	N/A
1991-96 V6 - 3.0L (6G72) [3000GT]	see dealer	N/A	N/A	N/A	N/A		3200003	N/A
1999-2003 V6 - 3.0L (6G72) [Galant, 00 Eclipse]	3100055	3600006	1-5/8"	LR	9 o'clock		N/A	N/A
1997-2007 V6 - 3.5L (6G74) [Diamante]	3100055	3600006	1-5/8"	LR	6 o'clock		N/A	N/A
2004-2011 V6 - 3.8L [Galant]	3100055	3600006	1-5/8"	LR	12 o'clock		N/A	N/A
LIGHT & MEDIUM DUTY TRUCKS								
4 Cylinder								
1983-89 L4 - 2.0L (G63B)	3100024	3600006	35 MM	RR	3 o'clock		N/A	N/A
1983-86 L4 - 2.3L (4D55) DIESEL	see dealer	3600006	40 MM	LR	9 o'clock		N/A	N/A
1987-90 L4 - 2.4L (G64B)	3100024	3600006	35 MM	RR	3 o'clock		N/A	N/A
1990-96 L4 - 2.4L (4G64)	3100024	3600006	35 MM	RR	3 o'clock		N/A	N/A
2003-2007 L4 - 2.4L (4G64) [Outlander]	3100024	3600006	35 MM	2nd LF	3 o'clock		N/A	N/A
2008-2011 L4 - 2.4L [Outlander]	3100111	3600083	Cartridge	LF	N/A		N/A	N/A
1997-2009 L4 - 2.4L (4G64) [Montero Sport]	3100024	3600006	35 MM	LF	3 o'clock		N/A	N/A
1983-89 L4 - 2.6L (G54B)	see dealer	3600006	40 MM	RF	6 o'clock		N/A	N/A
6 Cylinder								
1990-2005 V6 - 3.0L (6G72) [Truck,Montero]	3100055	3600006	1-5/8"	RR	9 o'clock		N/A	N/A
2007-2008 V6 - 3.0L (6B31) [Outlander]	see dealer	3600006	40 MM	RF	6 o'clock		N/A	N/A
1997-2005 V6 - 3.0L (6G72) [Montero Sport]	3100055	3600006	1-5/8"	RC	6 o'clock		N/A	N/A
2008-2011 V6 - 3.5L [Outlander]	3100007	3600005	30MM	CR	N/A		N/A	N/A
1999-2002 V6 - 3.5L (6G74) [Montero Sport]	3100055	3600006	1-5/8"	RC	6 o'clock		N/A	N/A
1995-2002 V6 - 3.5L (6G74) [Montero]	3100055	3600006	1-5/8"	RR	12 o'clock		N/A	N/A
2003-2011 V6 - 3.8L	3100055	3600006	1-5/8"	RR	12 o'clock		N/A	N/A
NISSAN								
AUTOMOTIVE								
4 Cylinder								
1966-80 L4 - 1.0, 1.2, 1.3, 1.4, 1.6L OHV (Conv)	3100016	3600006	35 MM	LF	12 o'clock		N/A	N/A
1972-82 L4 - 1.2, 1.4, 1.5L OHC (Conventional)	3100016	3600006	35 MM	LF	12 o'clock		N/A	N/A
1968-73 L4 - 1.3, 1.6L OHC (Conventional)	3100048	3600006	40 MM	LF or RR	12 o'clock		3200002	N/A
1976-81 L4 - 1.4L (A14), 1.5L (A15) (Transverse)	3100016	3600006	35 MM	LR	12 o'clock		N/A	N/A
1982-88 L4 - 1.5L (E15), 1.6L (E16) (Transverse)	3100074	3600004	30 MM	RR	8 o'clock		N/A	N/A
1989-90 L4 - 1.6L (GA16) (Transverse)	3100074	3600004	30 MM	RF	9 o'clock		N/A	N/A
1991-92 L4 - 1.6L (E16) (Transverse)	3100074	3600004	30 MM	RR	8 o'clock		N/A	N/A
1991-99 L4 - 1.6L (GA16DE) (Transverse)	3100074	3600004	30 MM	RF	9 o'clock		N/A	N/A
1987-89 L4 - 1.6L (CA16DE), 1.8L (CA18DE) (Trans)	3100074	3600004	30 MM	LF	4 o'clock		N/A	N/A
2011 L4 - 1.6L (MR16DDT) (Transverse)	see dealer	N/A	N/A	N/A	N/A		N/A	N/A
1983-87 L4 - 1.7L (CD17) (Transverse) DIESEL	3100074	3600004	30 MM	RR	8 o'clock		N/A	N/A
1984-88 L4 - 1.8L (CA18ET) (Conventional) TURBO	3100074	3600004	30 MM	RC	3 o'clock		3200002	N/A
1973-80 L4 - 1.8L (L18), 2.0L (L20) (Conventional)	3100048	3600006	40 MM	3RD RS	12 o'clock		N/A	N/A
2002-2006 L4 - 1.8L (QG18DE)	see dealer	N/A	N/A	N/A	N/A		N/A	N/A
2007-2011 L4 - 1.8L (MR20DE)	see dealer	N/A	N/A	N/A	N/A		N/A	N/A
1986-88 L4 - 2.0L (CA20) (Conventional)	3100074	3600004	30 MM	LR	6 o'clock		3200002	N/A
1982-89 L4 - 2.0L (CA20,CA20E) (Transverse)	3100074	3600004	30 MM	LF	7 o'clock		N/A	N/A
1991-99 L4 - 2.0L (GA20DE) (Transverse)	3100007	3600005	30 MM THD	RR	N/A		3200003	N/A
1980-85 L4 - 2.0L (Z20), 2.2L (Z22) (Conventional)	3100048	3600006	40 MM	LF	12 o'clock		N/A	N/A
2007-2011 L4 - 2.0L (MR18DE)	see dealer	N/A	N/A	N/A	N/A		N/A	N/A
2002-2007 L4 - 2.5L (QR25DE) (Transverse)	3100007	3600005	30 MM THD	RF	N/A		N/A	N/A
1989-2001 L4 - 2.4L (KA24E) (Transverse)	3100049	3600006	40 MM	LF	12 o'clock		3200003	N/A
1989-98 L4 - 2.4L (KA24E, KA24DE) (Conventional)	3100049	3600006	40 MM	LR	12 o'clock		3200003	N/A
6 Cylinder								
1974-80 L6 - 2.6L (L26)	3100016	3600006	35 MM	RF	12 o'clock		N/A	N/A
1970-85 L6 - 2.4L, 2.8L(L24, L28 E, ET)	3100016	3600006	35 MM	3RD RS	12 o'clock		N/A	N/A
1981-84 L6 - 2.8L(LD28) DIESEL	3100016	3600006	35 MM	LR	12 o'clock		N/A	750W
1986-93 V6 - 3.0L (VG30E, ET, DE) (Conventional)	3100009	3600004	30 MM	LR	6 o'clock		N/A	N/A
1986-94 V6 - 3.0L (VG30E, DE) (Transverse)	3100009	3600004	30 MM	LF	6 o'clock		N/A	N/A
1995-2001 V6 - 3.0L (VQ30DE) (Transverse)	3100007	3600005	30 MM THD	RF	N/A		N/A	N/A
2002-2011 V6 - 3.5L (VQ35DE)(Transverse)	3100007	3600005	30 MM THD	RF	N/A		N/A	N/A
2004-2009 V6 - 3.5L (VQ35DE, VQ35HR) (Conventional)	3100007	3600005	30 MM THD	LR	N/A		N/A	N/A

* Please confirm element orientation - improper position may result in heater or engine damage.

* Description of footnotes - see page 26. Circulation Heaters - see page 71. Lower Radiator Hose Heaters - see page 85.

MAKE, MODEL, YEAR & ENGINE	FREEZE PLUG HEATER (UNLESS OTHERWISE NOTED)					LOWER HOSE HEATER	CIRCULATION HEATER	
	HEATER PART No.	REPL. CORD PART No.	BORE DIAMETER	INSTALLATION LOCATION	POINT ELEMENT†	NOTES*	PART No.	WATTAGE
NISSAN - continued								
2010-2011 V6 - 3.7L (Conventional)	see dealer	N/A	N/A	N/A	N/A		N/A	N/A
2010-2011 V6 - 3.8L Turbo (VR38DETT)	see dealer	N/A	N/A	N/A	N/A		N/A	N/A
LIGHT & MEDIUM DUTY TRUCKS								
4 Cylinder								
1970-73 L4 - 1.6L OHC ENG	3100048	3600006	40 MM	LF or RR	12 o'clock		3200002	750W
1974-80 L4 - 1.8L (L18), 2.0L (L20)	3100048	3600006	40 MM	3RD RS	12 o'clock		N/A	750W
1981-89 L4 - 2.0L (Z20), 2.2L (Z22), 2.4L (Z24)	3100048	3600006	40 MM	LF	12 o'clock		N/A	750W
1990-98 L4 - 2.4L (KA24E)	3100049	3600006	40 MM	LR	12 o'clock		3200003	750W
1981-88 L4 - 2.2, 2.5L (SD25) DIESEL	3100016	3600006	35 MM	LF	6 o'clock		N/A	750W
2005-2007 L4 - 2.5L (QR25DE) (Conventional)	3100007	3600005	30 MM THD	LF	N/A		N/A	N/A
6 Cylinder								
1984-95 V6 - 3.0L (VG30E, VG30i)	3100009	3600004	30 MM	LR	6 o'clock		N/A	N/A
1993-98 V6 - 3.0L (VG30E) (Transverse) [Quest]	3100009	3600004	30 MM	LF	6 o'clock		N/A	N/A
1999-00 V6 - 3.3L (VG33) (Transverse) [Quest]	3100009	3600004	30 MM	LF	6 o'clock		N/A	N/A
1998-2004 V6 - 3.3L (VG33) (Conventional)	3100009	3600004	30 MM	LR	6 o'clock		N/A	N/A
2001-2011 V6 - 3.5L (VQ35DE) (Conventional)	3100007	3600005	30MM THD	LF	N/A		N/A	N/A
2005-2011 V6 - 4.0L (VQ40DE) (Conventional)	see dealer	N/A	N/A	N/A	N/A		N/A	N/A
8 Cylinder								
2004-2011 V8 - 5.6L (VK56DE)	3100007	3600005	30MM THD	RF	N/A		N/A	N/A
OLDSMOBILE								
AUTOMOTIVE								
4 Cylinder								
1982-89 L4 - 1.8L, 2.0L OHC (Brazil engine)	3100015	3600006	34 MM	2ND LF	1 or 3 o'clock		N/A	N/A
1982-84 L4 - 1.8L, 2.0L	3100014	3600006	34 MM	LF	12 o'clock		N/A	N/A
1985-86 L4 - 2.0L	3100062	3600006	42 MM	LF	4 o'clock		N/A	N/A
1987-92 L4 - 2.2L	3100081	3600006	42 MM	LF	9 o'clock		N/A	N/A
1993-96 L4 - 2.0L, 2.2L (Transverse)	3100081	3600006	42 MM	LF	9 o'clock		N/A	N/A
2002-2004 L4 2.2L (Ecotec) (Transverse)	3400019	3600083	CLAMP-ON	RR	N/A		N/A	N/A
1987-93 L4 - 2.3L QUAD IV	3100093	3600023	3/4" NPT	N/A	N/A		N/A	N/A
1994-95 L4 - 2.3L QUAD IV GEN II	3100001	3600002	1/2" NPT	N/A	N/A		N/A	N/A
1996-2001 L4 - 2.4L (Twin Cam)	3100001	3600002	3/4" NPT	N/A	N/A		N/A	N/A
1980-92 L4 - 2.5L (Transverse)	3100076	3600006	1-5/8"	LF	12 o'clock		3200003	N/A
1978-81 L4 - 2.5L (Conventional)	3100076	3600006	1-5/8"	LR	12 o'clock		3200003	N/A
6 Cylinder								
1980-86 V6 - 2.8L (Transverse)	3100014	3600006	34 MM	RS	3 o'clock		3200003	750W
1987-89 V6 - 2.8L (Transverse) (VIN W)	3100015	3600006	34 MM	CR	3 o'clock		N/A	N/A
1982-88 V6 - 3.0L (Transverse)	3100041	3600006	1-1/2"	LF	12 o'clock		N/A	750W
1989-99 V6 - 3.1L (Transverse)	3100015	3600006	34 MM	CR	3 o'clock		N/A	N/A
1992-97 V6 - 3.4L (Transverse)	3100015	3600006	34 MM	CR	3 o'clock		N/A	N/A
1999-2004 V6 - 3.4L (Transverse)	3100015	3600006	34 MM	CR	3 o'clock		N/A	N/A
1999-2002 V6 - 3.5L DOHC (Transverse)	see dealer	N/A	CLAMP-ON	N/A	N/A		N/A	N/A
1989-98 V6 - 3300, 3800 (Transverse)	3100041	3600006	1-1/2"	RF or LF	12 o'clock		N/A	N/A
1975-88 V6 - 3.8L (231 cu. in.) (Conventional)	3100039	3600006	1-1/2"	RR	12 o'clock		3200003	750W
1984-88 V6 - 3.8L (231 cu. in.) (Transverse)	3100041	3600006	1-1/2"	LF	3 o'clock		3200003	750W
1981-84 V6 - 4.1L (252 cu. in.) (Conventional)	3100039	3600006	1-1/2"	RR	12 o'clock		3200003	750W
1983-85 V6 - 4.3L DIESEL (Transverse)	3100039	3600006	1-1/2"	RF or RR	12 o'clock		N/A	750W
1982-85 V6 - 4.3L DIESEL (Conventional)	3100039	3600006	1-1/2"	LF or RF	12 o'clock		N/A	750W
1991-96 V6 - 4.3L	3100057	3600006	1-5/8"	LR	6 o'clock		N/A	750W
1968-76 L6 - 250 cu. in.	3100054	3600006	1-5/8"	LF or LR	6 or 12 o'clock		3200003	750W
8 Cylinder								
1979-85 V8 - 260 cu. in. DIESEL	3100039	3600006	1-1/2"	LR	12 o'clock		3200003	1500W
1975-82 V8 - 260 cu. in. GAS	3100039	3600006	1-1/2"	RF	6 o'clock		3200003	1500W
1997-2003 V8 - 4.0L [Aurora]	see dealer	N/A	CLAMP-ON	N/A	N/A		N/A	N/A
1980-81 V8 - 4.3L (265 cu. in.)	3100070	3600006	1-15/16"	LC	11 o'clock		3200003	1500W
1981-82 V8 - 4.4L (267 cu. in.)	3100057	3600006	1-5/8"	LR	9 o'clock		3200003	1500W
1980-90 V8 - 5.0L (307 cu. in.)	3100039	3600006	1-1/2"	LF or RF	12 o'clock		3200003	1500W
1979 V8 - 301 cu. in.	3100070	3600006	1-15/16"	LC	6 or 12 o'clock		3200003	1500W
1977-92 V8 - 305, 350 cu. in. (Chevrolet engine)	3100057	3600006	1-5/8"	LR	9 o'clock		3200003	1500W
1964-67 V8 - 330 cu. in.	3100039	3600006	1-1/2"	LF or RF	12 o'clock		3200004	1500W
1968-81 V8 - 350, 455 [Except Delmont] (Olds eng)	3100039	3600006	1-1/2"	LF or RF	12 o'clock		3200003	1500W
ALL V8 - 350 [Delmont]	3100039	3600006	1-1/2"	RC	12 o'clock		3200003	1500W
1967-76 V8 - 400 cu. in.	3100039	3600006	1-1/2"	LF or RC	12 o'clock		3200003	1500W
1975 V8 - 400 cu. in. [Vista Cruiser]	3100070	3600006	1-15/16"	LF	6 o'clock		3200003	1500W
1977-79 V8 - 403 cu. in.	3100039	3600006	1-1/2"	RF	12 o'clock		3200003	1500W
1978-85 V8 - 350 cu. in. DIESEL	3100039	3600006	1-1/2"	LF or RF	12 o'clock		N/A	1500W

† Please confirm element orientation - improper position may result in heater or engine damage.

* Description of footnotes - see page 26. Circulation Heaters - see page 71. Lower Radiator Hose Heaters - see page 85.

MAKE, MODEL, YEAR & ENGINE	FREEZE PLUG HEATER (UNLESS OTHERWISE NOTED)						LOWER HOSE HEATER	CIRCULATION HEATER
	HEATER PART No.	REPL. CORD PART No.	BORE DIAMETER	INSTALLATION LOCATION	POINT ELEMENT†	NOTES*	PART No.	WATTAGE
OLDSMOBILE - continued								
LIGHT & MEDIUM DUTY TRUCKS								
2004 L6 - 4.2L	3100005	3600005	28MM THD	LF	N/A		N/A	N/A
1991-96 V6 - 4.3L [Bravada]	3100054	3600006	1-5/8"	LR	12 o'clock		N/A	N/A
PONTIAC								
3 Cylinder								
1985-99 L3 - 1.0L	3400002	3600002	CLAMP-ON	N/A	N/A		3200001	N/A
4 Cylinder								
1987-99 L4 - 1.3L (Suzuki engine)	3400004	3600020	CLAMP-ON	N/A	N/A		3200001	N/A
1985-87 L4 - 1.5L (Transverse)	3100018	3600006	35 MM	CR	12 o'clock		N/A	N/A
1981-88 L4 - 1.6L OHV (Conventional)	3100014	3600006	34 MM	RF	6 o'clock		N/A	N/A
2004-2009 L4 - 1.6L [Wave]	3100008	3600003	36 MM	LF	N/A		N/A	N/A
1988-98 L4 (Suzuki engine) [Sunrunner]	3400003	3600002	CLAMP-ON	N/A	N/A		3200001	N/A
1988-93 L4 - 1.6L (Transverse) [Lemans]	3100015	3600006	34 MM	LF	3 o'clock		3200002	N/A
1982-84 L4 - 1.8L, 2.0L, OHV	3100014	3600006	34 MM	LF	12 o'clock		N/A	N/A
1982-87 L4 - 1.8L DIESEL	3100018	3600006	35 MM	RR	12 o'clock		N/A	N/A
1982-94 L4 - 1.8L, 2.0L OHC (Brazil engine)	3100015	3600006	34 MM	2ND LF	3 o'clock		N/A	N/A
2002-2009 L4 - 1.8L (1ZZFE) (Transverse)[Vibe]	3100129	3600083	Cartridge	LR	N/A		N/A	N/A
2007-2009 L4 - 2.0L (Ecotec Turbo) (Conventional)	see dealer	3600082	CLAMP-ON	N/A	N/A		N/A	N/A
1995-2001 L4 - 2.2L	3100081	3600006	42 MM	LF	9 o'clock		N/A	N/A
2002-2004 L4 - 2.2L (Ecotec) (Transverse)	3400019	3600083	CLAMP-ON	RR	N/A		N/A	N/A
2005-2009 L4 - 2.2L (Ecotec) (Transverse)	3400020	3600082	CLAMP-ON	RR	N/A		N/A	N/A
1985-86 L4 - 2.0L	3100062	3600006	42 MM	LF	4 o'clock		N/A	N/A
1987-93 L4 - 2.3L QUAD IV	3100093	3600003	3/4" NPT	N/A	N/A		N/A	N/A
1994-95 L4 - 2.3L QUAD IV GEN II	3100001	3600002	1/2" NPT		N/A		N/A	N/A
2006-2009 L4 - 2.4L (Ecotec) (Transverse)	340 0020	3600082	CLAMP-ON	RR	N/A		N/A	N/A
2006-2009 L4 - 2.4L (Ecotec) (Conventional)	3400020	3600082	CLAMP-ON	RF	N/A		N/A	N/A
1996-2001 L4 - 2.4L (Twin Cam)	3100001	3600002	1/2" NPT		N/A		N/A	N/A
2009 L4 - 2.4L (Toyota Engine) [Vibe]	3100129	3600083	cartridge	LR	N/A		N/A	N/A
1977-87 L4 - 2.5L (Conventional)	3100076	3600006	1-5/8"	LR	6 or 12 o'clock		3200003	750W
1980-94 L4 - 2.5L (Transverse)	3100076	3600006	1-5/8"	LF	12 o'clock		3200003	750W
6 Cylinder								
1980-86 V6 - 2.8L (Transverse)	3100014	3600006	34 MM	RS	3 o'clock		3200003	N/A
1985-89 V6 - 2.8L (Transverse) (MIN W)	3100015	3600006	34 MM	CR	3 o'clock		N/A	N/A
1982-89 V6 - 2.8L (Conventional)	3100014	3600006	34 MM	RFF IN BLOCK	3 o'clock		3200003	750W
1985-88 V6 - 3.0L (Transverse)	3100041	3600006	1-1/2"	LF	12 o'clock		3200003	750W
1990-97 V6 - 3.1, 3.4L (Conventional)	3100015	3600006	34 MM	LC or RC	3 o'clock		N/A	N/A
1988-2002 V6 - 3.1L (Transverse)	3100015	3600006	34 MM	CR	3 o'clock		N/A	N/A
1992-97 V6 - 3.4L (Transverse)	3100015	3600006	34 MM	CR	3 o'clock		N/A	N/A
1999-2004 V6 - 3.4 (Transverse)	3100015	3600006	34 MM	CR	3 o'clock		N/A	N/A
2005-2009 V6 - 3.4 (Transverse) [Torrent]	3100109	3600082	28 MM THD	CR	N/A		N/A	N/A
2005-200 V6 - 3.5L (Transverse)	3100109	3600082	28 MM THD	CR	N/A		N/A	N/A
2007-2009 V6 - 3.6L (Transverse)	3100110	3600082	Cartridge	LR	N/A		N/A	N/A
2008-2009 V6 - 3.6L (Conventional)	3100110	3600082	Cartridge	LR	N/A		N/A	N/A
2005-2009 V6 - 3.9L (Transverse)	3100109	3600082	28 MM THD	CR	N/A		N/A	N/A
1988-2004 V6 - 3300, 3800 (Transverse)	3100041	3600006	1-1/2"	RF or LF	12 o'clock		3200003	N/A
2005-2009 V6 - 3800 (Transverse)	3100109	3600082	28 MM THD	CR	N/A		N/A	N/A
1996-2002 V6 - 3.8L Firebird	3100041	3600006	1-1/2"	RF	12 o'clock		N/A	N/A
1976-88 V6 - 3.8L (231 cu. in.) (Conventional)	3100039	3600006	1-1/2"	RR	12 o'clock		3200003	1000W
1987-89 V6 - 3.8L (231 cu. in.) (Transverse)	3100041	3600006	1-1/2"	LF	3 o'clock		3200003	1000W
1980-81 V6 - 3.8L (229 cu. in.)	3100057	3600006	1-1/2"	LR	6 o'clock		3200003	1000W
1982-83 V6 - 4.1L (252 cu. in.)	3100039	3600006	1-1/2"	RR	12 o'clock		3200003	1000W
1985-87 V6 - 4.3L	3100057	3600006	1-5/8"	LR	6 o'clock		3200003	1000W
1982-85 V6 - 4.3L DIESEL	3100039	3600006	1-1/2"	LF or LR	12 o'clock		N/A	1000W
1955-73 L6 - 194, 230, 250 cu. in.	3100054	3600006	1-5/8"	LF	12 o'clock		3200003	1000W
1974-78 L6 - 250 cu. in.	3100054	3600006	1-5/8"	LR	12 o'clock		3200003	1000W
8 Cylinder								
1975-76 V8 - 260 cu. in.	3100039	3600006	1-1/2"	RF	6 o'clock		3200003	1500W
1980-81 V8 - 4.3L (265 cu. in.)	3100070	3600006	1-15/16"	LC	11 o'clock		3200003	1500W
1978-82 V8 - 4.4L (267 cu. in.)	3100057	3600006	1-5/8"	LR	9 o'clock		3200004	1500W
1977-81 V8 - 301 cu. in.	3100070	3600006	1-15/16"	LR	6 or 12 o'clock		3200003	1500W
1958-94 V8 - 283,305,307,327,350,400 (Red) cu. in.	3100057	3600006	1-5/8"	LR	9 o'clock		3200003	1500W
1973-79 V8 - 350, 400, 455 (Blue) cu. in.	3100070	3600006	1-15/16"	LC or LR	12 o'clock		3200003	1500W
2005-2007 V8 - 5.3L (Transverse)	3100109	3600082	28 MM THD	RF	N/A		N/A	N/A
1998-2002 V8 - 5.7L Gen 3	3100005	3600005	28 MM THD	LR	N/A		N/A	1500W
2004 V8 - 5.7L Gen 3	3100005	3600005	28 MM THD	LR	N/A		N/A	1500W

† Please confirm element orientation - improper position may result in heater or engine damage.

* Description of footnotes - see page 26. Circulation Heaters - see page 71. Lower Radiator Hose Heaters - see page 85.

MAKE, MODEL, YEAR & ENGINE	FREEZE PLUG HEATER (UNLESS OTHERWISE NOTED)					LOWER HOSE HEATER	CIRCULATION HEATER	
	HEATER PART No.	REPL. CORD PART No.	BORE DIAMETER	INSTALLATION LOCATION	POINT ELEMENT†	NOTES*	PART No.	WATTAGE
PONTIAC - continued								
1980-85 V8 - 5.7L (350 cu. in.) DIESEL	3100039	3600006	1-1/2"	LF or RF	12 o'clock		N/A	1500W
2005-2006 V8 - 6.0L LS2	3100109	3600082	28MM THD	LF	N/A		N/A	N/A
2008-2009 V8 - 6.0L	3100109	3600082	28MM THD	LF	N/A		N/A	N/A
2009 V8 - 6.2L	3100109	3600082	28MM THD	LF	N/A		N/A	N/A
1962-70 V8 - 396, 409, 427 cu. in.	3100065	3600006	1-3/4"	RC or LF	3 or 12 o'clock		3200003	1500W
1977-89 V8 - 307,350, 403 cu. in. (Oldsmobile eng)	3100039	3600006	1-1/2"	RF	12 o'clock		3200003	1500W
1970-77 V8 - 454 cu. in.	3100065	3600006	1-3/4"	RC	6 o'clock		3200003	1500W
1971-81 V8 - 350 cu. in. (Buick engine)	3100039	3600006	1-1/2"	LF or RF	12 o'clock		N/A	1500W
PORSCHE								
6 Cylinder								
1998-2011 H6 - 2.5L, 2.7L, 3.0L, 3.2L, 3.6L, 3.8L	see dealer	N/A	N/A	N/A	N/A		N/A	N/A
2004-2007 V6 - 3.2L [Cayenne]	3100010	3600005	30 MM	CFF	10 o'clock		N/A	N/A
2007-2011 V6 - 3.6L [Cayenne]	see dealer	N/A	N/A	N/A	N/A		N/A	N/A
2011 V6 - 3.6L [Panamera]	see dealer	N/A	N/A	N/A	N/A		N/A	N/A
8 Cylinder								
2003-2006 V8 - 4.5L [Cayenne & Turbo]	see dealer	N/A	N/A	RFF	N/A		N/A	N/A
2007-2010 V8 - 4.8L [Cayenne & Panamera]	see dealer	N/A	N/A	N/A	N/A		N/A	N/A
LAND ROVER								
4 Cylinder								
1958-UP L4 - 120.8 cu. in. Gas/Diesel [Land Rover]	3100070		1-15/16"	LC	6 o'clock		3200002	N/A
6 Cylinder								
1958-UP L6 - 161, 182.7 cu. in.	3100003	3600001	1" NPT	N/A	N/A		N/A	N/A
2002-2005 V6 - 2.5L	see dealer	N/A	N/A	N/A	N/A		N/A	N/A
2007-2011 L6 - 3.2L	see dealer	N/A	N/A	N/A	N/A		N/A	N/A
8 Cylinder								
1987-2004 V8 - 3.9, 4.0, 4.2, 4.6L	3100039	3600006	1-1/2"	LC	12 o'clock		N/A	N/A
2003-2004 V8 - 4.4L (BMW Engine)	see dealer	N/A	N/A	N/A	N/A		N/A	N/A
2005-2009 V8 - 4.2L, 4.4L (Jaguar Engine)	see dealer	N/A	30 MM THD	LR	N/A		N/A	N/A
2010-2011 V8 - 5.0L	see dealer	N/A	30 MM THD	LR	N/A		N/A	N/A
SAAB								
4 Cylinder								
1975-84 L4 - 2.0, 2.1L	3100056	3600006	1-5/8"	RR	3 o'clock		N/A	750W
1985-93 L4 - 2.0, 2.1L	3100004	3600084	26 MM THD	N/A	N/A		N/A	N/A
2003-2011 L4 2.0L Turbo	see dealer	N/A	CLAMP-ON	N/A	N/A		N/A	N/A
2004-2005 H4 2.0L Turbo (Subaru Engine)	3100008	3600003	36 MM THD	Left Front Bottom	N/A		N/A	N/A
1990-2005 L4 - 2.3L (B234)	3100033	3600006	36 MM	LF	9 o'clock		N/A	N/A
2004-2005 H4 2.5L (Subaru Engine)	3100008	3600003	36 MM THD	Left Front Bottom	N/A		N/A	N/A
6 Cylinder								
1994-95 V6 - 2.5L	see dealer	N/A	N/A	N/A	N/A		N/A	N/A
2006-2011 V6 - 2.8L Turbo	see dealer	N/A	N/A	N/A	N/A		N/A	N/A
1999-2003 V6 - 3.0L	3100006	3600005	LF	N/A	N/A		N/A	N/A
2005-2007 L6 - 4.2L (Conventional)	3100109	3600082	28 MM THD	LF	N/A		N/A	N/A
8 Cylinder								
2005-2007 V8 - 5.3L (Conventional)	3100109	3600082	28 MM THD	LR	N/A		N/A	N/A
SATURN								
4 Cylinder								
1991-2001 L4 - 1.9L	see dealer	N/A	CLAMP-ON	N/A	N/A		N/A	N/A
2004 L4 - 2.0L (Ecotec) (Transverse)	3400019	3600083	CLAMP-ON	RR	N/A		N/A	N/A
2005-2006 L4 - 2.0L (Ecotec) (Transverse)	3400020	3600082	CLAMP_ON	RR	N/A		N/A	N/A
2007-2009 L4 - 2.0L (Ecotec Turbo) (Conventional)	see dealer	3600082	CLAMP-ON	N/A	N/A		N/A	N/A
2000-2004 L4 - 2.2L (Ecotec) (Transverse)	3400019	3600083	CLAMP-ON	RR	N/A		N/A	N/A
2005-2006 L4 - 2.2L (Ecotec) (Transverse)	3400020	3600082	CLAMP_ON	RR	N/A		N/A	N/A
2006-2009 L4 - 2.4L (Ecotec) (Transverse)	3400020	3600082	CLAMP_ON	RR	N/A		N/A	N/A
2006-2009 L4 - 2.4L (Ecotec) (Conventional)	3400020	3600082	CLAMP_ON	RF	N/A		N/A	N/A
6 Cylinder								
2000-2004 V6 - 3.0L	3100006	3600005	28MM THD	LF	N/A		N/A	N/A
2005-2006 V6 - 3.0L	see dealer	N/A	N/A	N/A	N/A		N/A	N/A
2007-2009 V6 - 3.5L (Transverse)	3100109	3600082	28 MM THD	LR	N/A		N/A	N/A
2007-2009 V6 - 3.6L (Transverse)	3100110	3600082	cartridge	LR	N/A		N/A	N/A
LIGHT & MEDIUM DUTY TRUCKS & VANS								
4 Cylinder								
2002-2004 L4 - 2.2L	3400019	3600083	CLAMP-ON	RR	N/A		N/A	N/A
2005-2007 L4 - 2.2L	3400020	3600082	CLAMP_ON	RR	N/A		N/A	N/A

† Please confirm element orientation - improper position may result in heater or engine damage.

* Description of footnotes - see page 26. Circulation Heaters - see page 71. Lower Radiator Hose Heaters - see page 85.

MAKE, MODEL, YEAR & ENGINE	FREEZE PLUG HEATER (UNLESS OTHERWISE NOTED)					LOWER HOSE HEATER	CIRCULATION HEATER
	HEATER PART No.	REPL. CORD PART No.	BORE DIAMETER	INSTALLATION LOCATION	POINT ELEMENT†	NOTES*	PART No.
SATURN - continued							
6 Cylinder							
2002-2004 V6 - 3.0L	3100006	3600005	28MM THD	LF	N/A		N/A N/A
2005-2007 V6 - 3.0L	see dealer	N/A	N/A	N/A	N/A		N/A N/A
2004-2007 V6 - 3.5L [Honda Engine]	3100006	3600005	28MM THD	LF	N/A		N/A N/A
2005-2009 V6 - 3.5L	3100109	3600082	28 MM THD	LR	N/A		N/A N/A
2007-2009 V6 - 3.6L (Transverse)	3100110	3600082	cartridge	LR	N/A		N/A N/A
SCION							
4 Cylinder							
2004-2009 L4 - 1.5L (1NZ-FE)	3100129	3600083	cartridge	LR	N/A		N/A N/A
2004-2011 L4 2.4L	3100129	3600083	cartridge	LR	N/A		N/A N/A
2011 L4 - 2.5L (2AR-FE)	see dealer	N/A	N/A	N/A	N/A		N/A N/A
SMART							
3 Cylinder							
2005-2007 L3 DIESEL [ForTwo]	see dealer	N/A	N/A	N/A	N/A		N/A N/A
2008-2011 L3 GASOLINE [ForTwo]	see dealer	N/A	N/A	N/A	N/A		N/A N/A
SUBARU							
ALL H4 & H6 - 1980-2011	3100008	3600003	36 MM THD	Left Front Bottom	N/A		N/A N/A
2008-2011 H6 - 3.6L	see dealer	N/A	36 MM THD	N/A	N/A		N/A N/A
SUZUKI							
3 Cylinder							
1985-00 L3 - 1.0L	3400002	3600002	CLAMP-ON	N/A	N/A		3200001 N/A
4 Cylinder							
1985-99 L4 - 1.3L	3400004	3600020	CLAMP-ON	N/A	N/A		3200001 N/A
1989-2001 L4 - 1.6L	3400003	3600002	CLAMP-ON	N/A	N/A		3200001 N/A
2005-2006 L4 - 1.6L [Swift]	see dealer	N/A	N/A	N/A	N/A		N/A N/A
2011 L4 1.6L [Swift]	see dealer	N/A	N/A	N/A	N/A		N/A N/A
1998-2003 L4 - 1.8L	see dealer	N/A	30 MM	LR	N/A		N/A N/A
1999-2003 L4 - 2.0L	see dealer	N/A	30 MM	LR	N/A		N/A N/A
2003-2004 L4 - 2.0L [Aerio]	see dealer	N/A	N/A	N/A	N/A		N/A N/A
2004-2005 L4 - 2.0L [Reno]	see dealer	N/A	N/A	N/A	N/A		N/A N/A
2007-2011 L4 - 2.0L [SX4]	see dealer	N/A	N/A	N/A	N/A		N/A N/A
2005-2007 L4 - 2.3L [Aerio]	see dealer	N/A	N/A	N/A	N/A		N/A N/A
2009-2011 L4 - 2.4L (J24B) [Vitara, Kizashi]	see dealer	N/A	N/A	N/A	N/A		N/A N/A
6 Cylinder							
2004-2006 L6 - 2.5L	see dealer	N/A	N/A	N/A	N/A		N/A N/A
1999-2003 V6 - 2.5L	see dealer	N/A	CLAMP-ON	LF	N/A		N/A N/A
2004 L6 - 2.5L	see dealer	N/A	CLAMP-ON				
2001-2007 V6 - 2.7L	see dealer	N/A	CLAMP-ON	LF	N/A		N/A N/A
2008-2009 V6 - 3.2L	3100110	3600082	cartridge	LR	N/A		N/A N/A
2007-2010 V6 - 3.6L [XL7]	3100110	3600082	cartridge	LR	N/A		N/A N/A
2011 V6 - 4.0L [Equator]	see dealer	N/A	N/A	N/A	N/A		N/A N/A
TOYOTA							
AUTOMOTIVE							
4 Cylinder							
1967-80 L4 - 1.1L (K), 1.2L (3K, 3KC)	3100016	3600006	35 MM	LF	6 o'clock		N/A N/A
1981-85 L4 - 1.3L (4K, 4KE)	3100021	3600006	35 MM	LF	6 o'clock		N/A N/A
1980-87 L4 - 1.5L (3A, 1AC, 3AC)	3100049	3600006	40 MM	LC	12 o'clock		N/A N/A
1988-90 L4 - 1.5L (3E)	3100021	3600006	35 MM	LF	10-12 o'clock		N/A N/A
1990-94 L4 - 1.5L (3EE)	3100019	3600006	35 MM	LF	12 o'clock		N/A N/A
1992-99 L4 - 1.5L (5EFE)	3100011	3600004	30 MM	2ND RF	3 o'clock		N/A N/A
2000-2011 L4 - 1.5L (1NZ-FE)	3100129	3600083	cartridge	LR	N/A		N/A N/A
2004-2009 L4 - 1.5L (1NZ-FXE) [Prius]	see dealer	N/A	cartridge	LR	N/A		N/A N/A
1983-86 L4 - 1.6L (4AC) (Conventional)	3100049	3600006	40 MM	2ND LF	12 o'clock		N/A N/A
1985-97 L4 - 1.6L (4AF, 4AFE) (Transverse)	3100049	3600006	40 MM	CF	12 o'clock		N/A N/A
1984-87 L4 - 1.6L (4AC) (Transverse)	3100049	3600006	40 MM	2ND LF	12 o'clock		N/A N/A
1985-88 L4 - 1.6L (4AGE) (Conventional)	3100021	3600006	35 MM	RC	9 or 12 o'clock		N/A N/A
1985-89 L4 - 1.6L (4AGE) (Mid engine)	3100021	3600006	35 MM	RF	12 o'clock		N/A N/A
1988-91 L4 - 1.6L (4AGE) (Transverse)	3100021	3600006	35 MM	LR	9 or 12 o'clock		N/A N/A
1971-82 L4 - 1.6L (2TC), 1.8L (3TC)	3100075	3600004	35 MM	LF	9 o'clock		N/A N/A
1970-78 L4 - 1.8L (8R, 8RC)	3100048	3600006	40 MM	LC	12 o'clock		N/A N/A
1966-80 L4 - 1.8L (3R, 3RB, 3RC)	3100071	3600006	50 MM	LF	12 o'clock		N/A N/A
1993-97 L4 - 1.8L (7AFE) (Transverse)	3100049	3600006	40 MM	CF	12 o'clock		N/A N/A
1998-2011 L4 - 1.8L (1ZZFE) (Transverse)	3100129	3600083	cartridge	LR	N/A		N/A N/A
2010-2011 L4 - 1.8L (2ZR-FXE) [Prius]	see dealer	N/A	cartridge	LR	N/A		N/A N/A
94-2002 V8 - 7.3L (T444E)	3100129	3600083	cartridge	LR	N/A		N/A N/A

† Please confirm element orientation - improper position may result in heater or engine damage.

* Description of footnotes - see page 26. Circulation Heaters - see page 71. Lower Radiator Hose Heaters - see page 85.

MAKE, MODEL, YEAR & ENGINE	FREEZE PLUG HEATER (UNLESS OTHERWISE NOTED)					LOWER HOSE HEATER	CIRCULATION HEATER	
	HEATER PART No.	REPL. CORD PART No.	BORE DIAMETER	INSTALLATION LOCATION	POINT ELEMENT†	NOTES*	PART No.	WATTAGE
TOYOTA - continued								
1972-74 L4 - 2.0L (18RC)	3100049	3600006	40 MM	RR	12 o'clock		N/A	N/A
1987-91 L4 - 2.0L (3SFE)	3100098	3600006	35 MM	2ND RR	9 o'clock		N/A	N/A
1986-89 L4 - 2.0L (3SGE)	3100019	3600006	35 MM	2ND RR	9 or 12 o'clock		N/A	N/A
1983-86 L4 - 2.0L (2SE,2SGE)	3100049	3600006	40 MM	2ND LF	12 o'clock		N/A	N/A
1975-80 L4 - 2.2L (20R)	3100049	3600006	40 MM	RF	6 o'clock		N/A	N/A
1991-93 L4 - 2.2L (5SFE) MR2	3100021	3600006	35 MM	2ND LR	9 o'clock		N/A	N/A
1990-95 L4 - 2.2L (5SFE) [Celica]	3100049	3600006	40 MM	2ND LF	12 o'clock		N/A	N/A
1990-2001 L4 - 2.2L (5SFE) (Transverse)	3100049	3600006	40 MM	2ND LF	12 o'clock		N/A	N/A
1990-93 L4 - 2.2L (5SFE) (Mid engine)	3100049	3600006	40 MM	2ND LR	12 o'clock		N/A	N/A
1981-85 L4 - 2.4L (22R, 22RE)	3100049	3600006	40 MM	RF	10 o'clock		N/A	N/A
2002-2008 L4 - 2.4L (2AZ-FE)	3100129	3600083	cartridge	LR	N/A		N/A	N/A
2009-2011 L4 - 2.5L (2AR-FE)	see dealer	N/A	cartridge	LR	N/A		N/A	N/A
6 Cylinder								
1989-91 V6 - 2.5L (2VZFE)	3100019	3600006	35 MM	CF	6 o'clock		N/A	N/A
1992-96 V6 - 3.0L (3VZFE)	3100021	3600006	35 MM	LF	3 o'clock		N/A	N/A
1994-2006 V6 - 3.0L (1MZ-FE)	3100029	3600006	35 MM	RF	3 o'clock		N/A	N/A
1966-71 L6 - 2.2L (2M)	3100048	3600006	40 MM	LF	12 o'clock		N/A	750W
1971-79 L6 - 2.6L (4M)	3100049	3600006	40 MM	RR	5 o'clock		3200002	750W
1979-88 L6 - 2.6L (4ME), 2.8L (5ME, 5MGE)	3100049	3600006	40 MM	RF	10 o'clock		N/A	750W
1986-95 L6 - 2.8L (5MGE)	3100049	3600006	40 MM	LF	10-12 o'clock		N/A	N/A
1986-95 L6 - 3.0L (7MGE)	3100049	3600006	40 MM	LF	10-12 o'clock		N/A	N/A
2004-2006 V6 - 3.3L	3100029	3600006	35 MM	RF	3 o'clock		N/A	N/A
2005-2011 V6 - 3.5L (2GR-FE)	see dealer	N/A	Cartridge	LF	N/A		N/A	N/A
LIGHT & MEDIUM DUTY TRUCKS & VANS								
4 Cylinder								
1981-87 L4 - 1.8L (L), 2.2L (2L,2LT) DIESEL	3100024	3600006	35 MM	LR	12 o'clock		N/A	750W
1996-00 L4 - 2.0L (3SFE) [RAV4]	3100098	3600006	35 MM	2ND RR	9 o'clock		N/A	N/A
2001-2005 L4 - 2.0L [RAV4]	3100129	3600083	cartridge	LR	N/A		N/A	N/A
1984-89 L4 - 2.0L (3YE), 2.2L (4YE)	3100019	3600006	35 MM	LR	9-12 o'clock		N/A	N/A
1972-74 L4 - 2.0L (18RC)	3100049	3600006	40 MM	RR	12 o'clock		N/A	750W
1975-80 L4 - 2.2L (20R)	3100049	3600006	40 MM	RF	6 o'clock		N/A	750W
1981-98 L4 - 2.4L (22R, 22RE, 22RTE)	3100049	3600006	40 MM	RF	10 o'clock		N/A	750W
1991-97 L4 - 2.4L (2TZ-FE) [Previal]	3100022	3600006	35 MM	BOTTOM RF	9 o'clock		N/A	N/A
2001-2011 L4 - 2.4L	3100129	3600083	cartridge	LR	N/A		N/A	N/A
1994-2011 L4 - 2.7L	see dealer	N/A	N/A	N/A	N/A		N/A	N/A
2009-2011 L4 - 2.7L (1AR-FE) (Transverse)	see dealer	N/A	N/A	N/A	N/A		N/A	N/A
1981-87 L4 - 3.4L (3B) DIESEL	3100021	3600006	35 MM	LR	11-12 o'clock		N/A	750W
6 Cylinder								
1988-98 V6 - 3.0L (3VZE)	3100098	3600006	35 MM	LF or 2ND LF	3 o'clock		N/A	N/A
1998-2003 V6 - 3.0L (1MZ-FE)	3100029	3600006	35 MM	RF	3 o'clock		N/A	N/A
2004-2006 V6 - 3.3L (2MZFE)	3100029	3600006	35 MM	RF	3 o'clock		N/A	N/A
1997-2003 V6 - 3.4L (5VZ-FE)	see dealer	N/A	N/A	N/A	N/A		N/A	N/A
2003-2011 V6 - 4.0L (1GR-FE)	3100129	3600083	cartridge	LR	N/A		N/A	N/A
1985-87 L6 - 3.9L (2H) DIESEL	3100021	3600006	35 MM	RR	3 or 5 o'clock		N/A	750W
8 Cylinder								
2010-2011 V8 - 4.6L	see dealer	N/A	N/A	N/A	N/A		N/A	N/A
1998-2009 V8 - 4.7L (2UZ-FE)	see dealer	N/A	35 MM	2ND RF	N/A		N/A	N/A
2007-2011 V8 - 5.7L (3UR-FE)	3100129	3600083	cartridge	LR	N/A		N/A	N/A
VOLKSWAGEN								
4 Cylinder								
1962-76 L4 - ALL Air Cooled, except 411, 412	see dealer	N/A	N/A	N/A	N/A		N/A	N/A
1971-76 L4 - 411, 412	see dealer	N/A	N/A	N/A	N/A		N/A	N/A
1974-94 L4 - 1.5L, 1.6L &, 1.7L Gas/Diesel (Conv)	3100034	3600016	36.5 MM	2ND RF	6 o'clock		3200001	N/A
1974-94 L4 - 1.5L, 1.6L, & 1.7L Gas/Diesel (Trans)	3100034	3600016	36.5 MM	CR or RR	6 o'clock		3200001	N/A
1987-95 L4 - 1.8L (Conventional)	3100034	3600016	36.5 MM	RF	12 o'clock		N/A	N/A
1983-97 L4 - 1.8L (Transverse)	3100034	3600016	36.5 MM	CR or RR	12 o'clock		N/A	N/A
1998-2005 L4 - 1.8L (TURBO)	see dealer	N/A	N/A	N/A	N/A		N/A	N/A
1993-97 L4 - 1.9L TURBO DIESEL	3100034	3600016	36.5 MM	LR or CR	6 o'clock		N/A	N/A
1998-99 L4 - 1.9L TURBO DIESEL (Direct Injection)	3100034	3600016	36.5 MM	LR	N/A		N/A	N/A
2000-2005 L4 - 1.9L TURBO DIESEL (Direct Injection)	see dealer	N/A	N/A	N/A	N/A		3305002	750 Watt
1991-99 L4 - 2.0L (Transverse)	3100034	3600016	36.5 MM	CR or RR	6 o'clock		N/A	N/A
1998-2005 L4 - 2.0L [Beetle]	see dealer	N/A	N/A	N/A	N/A		N/A	N/A
2000-2011 L4 - 2.0L	see dealer	N/A	N/A	N/A	N/A		N/A	N/A
2004-2006 L4 - 2.0L DIESEL (Direct Injection)	see dealer	N/A	N/A	N/A	N/A		N/A	750 Watt

† Please confirm element orientation - improper position may result in heater or engine damage.

* Description of footnotes - see page 26. Circulation Heaters - see page 71. Lower Radiator Hose Heaters - see page 85.

MAKE, MODEL, YEAR & ENGINE	FREEZE PLUG HEATER (UNLESS OTHERWISE NOTED)						LOWER HOSE HEATER	CIRCULATION HEATER
	HEATER PART No.	REPL. CORD PART No.	BORE DIAMETER	INSTALLATION LOCATION	POINT ELEMENT†	NOTES*	PART No.	WATTAGE
VOLKSWAGEN - continued								
2009-2011 L4 - 2.0L DIESEL	see dealer	N/A	N/A	N/A	N/A		N/A	N/A
2006-2011 L4 - 2.0L TURBO FSI & TSI	see dealer	N/A	N/A	N/A	N/A		N/A	N/A
5 Cylinder								
1987-95 L5 - 2.2L, 2.3L	3100035	3600016	36.5 MM	RF or 2ND RF	3 o'clock		N/A	N/A
2005-2011 L5 - 2.5L	see dealer	N/A	N/A	N/A	N/A		N/A	N/A
6 Cylinder								
1993-2002 VR6 - 2.8L (Transverse)	see dealer	N/A	N/A	N/A	N/A		N/A	N/A
2003-2004 VR6 24V - 2.8L (Transverse)	see dealer	N/A	N/A	N/A	N/A		N/A	N/A
2004 VR6 24V - 3.2L (Transverse)	see dealer	N/A	N/A	N/A	N/A		N/A	N/A
2008 VR6 24V - 3.2L (Transverse)	see dealer	N/A	N/A	N/A	N/A		N/A	N/A
1998-2004 V6 - 2.8L (Conventional)	see dealer	N/A	N/A	N/A	N/A		N/A	N/A
2006-2011 VR6 - 3.6L (Transverse)	see dealer	N/A	N/A	N/A	N/A		N/A	N/A
8 Cylinder								
2003-2004 W8 - 4.0L	see dealer	N/A	N/A	N/A	N/A		N/A	N/A
2004-2006 V8 - 4.2L	see dealer	N/A	N/A	N/A	N/A		N/A	N/A
12 Cylinder								
2004-2006 W12 - 6.0L	see dealer	N/A	N/A	N/A	N/A		N/A	N/A
LIGHT & MEDIUM DUTY TRUCKS & VANS								
4 Cylinder								
2009-2011 L4 - 2.0L TURBO TSI	see dealer	N/A	N/A	N/A	N/A		N/A	N/A
5 Cylinder								
1992-95 L5 - 2.5L	see dealer	N/A	N/A	N/A	N/A		N/A	N/A
6 Cylinder								
2002-2003 VR6 24V - 2.8L (Transverse)	see dealer	N/A	N/A	N/A	N/A		N/A	N/A
2010-2011 V6 - 3.0L DIESEL	see dealer	N/A	N/A	N/A	N/A		N/A	N/A
2003-2007 VR6 - 3.2L (Conventional)	3100010		30 MM	CFF	10 o'clock		N/A	N/A
2007-2009 VR6 - 3.6L (Conventional)	see dealer	N/A	N/A	N/A	N/A		N/A	N/A
2009 V6 - 3.8L (Transverse)	see dealer	N/A	N/A	N/A	N/A		N/A	N/A
2009 V6 - 4.0L (Transverse)	see dealer	N/A	N/A	N/A	N/A		N/A	N/A
8 Cylinder								
2003-2011 V8 - 4.2L	see dealer	N/A	N/A	N/A	N/A		N/A	N/A
10 Cylinder								
2004-2008 V10 - 5.0L DIESEL	see dealer	N/A	N/A	N/A	N/A		N/A	N/A
VOLVO								
4 Cylinder								
2000-2003 L4 - 1.9L	see dealer	N/A	N/A	N/A	N/A		N/A	N/A
1985-91 L4 - 2.3L (B230)*	3100047	3600006	40 MM	RF	9 o'clock		3200002	750W
1991-96 L4 - 2.3L (B230)	3100052	3600006	40 MM	RF	9 o'clock		N/A	N/A
1989-90 L4 - 2.3L (B234)	3100052	3600006	40 MM	RF	9 o'clock		N/A	N/A
1962-79 L4 - 1.8L, 2.0L	3100064	3600006	1-3/4"	RR	3 o'clock		3200002	750W
1976-84 L4 - 2.1L, 2.3L (B21,B23)	3100064	3600006	1-3/4"	RR	9 o'clock		3200002	750W
5 Cylinder								
1993-2006 L5 - 2.3L (Transverse)	see dealer	N/A	N/A	N/A	N/A		N/A	N/A
1993-2011 L5 - 2.4L (Transverse)	see dealer	N/A	N/A	N/A	N/A		N/A	N/A
2003-2011 L5 - 2.5L (Transverse)	see dealer	N/A	N/A	N/A	N/A		N/A	N/A
6 Cylinder								
1976-90 V6 - 2.7L, 2.8L	3100031	3600006	36 MM	RRF IN HEAD	9 o'clock		3200002	750W
1980-86 L6 - 2.4L DIESEL	3100034	3600016	36.5 MM	RC	6 o'clock		N/A	750W
1969-79 L6 - 3.0L	3100064	3600006	1-3/4"	RR	9 o'clock		N/A	750W
1992-98 L6 - 3.0L	see dealer	N/A	N/A	N/A	N/A		N/A	N/A
1999-2006 L6 - 2.9L (Transverse, inc Turbo)	see dealer	N/A	N/A	N/A	N/A		N/A	N/A
2010-2011 L6 - 3.0L Turbo (Transverse)	see dealer	N/A	N/A	N/A	N/A		N/A	N/A
2007-2011 L6 - 3.2L (Transverse)	see dealer	N/A	N/A	N/A	N/A		N/A	N/A
8 Cylinder								
2006-2011 V8 - 4.4L (Transverse)	3100002	3600001	3/4" NPT	LR	N/A		N/A	N/A

Automotive Footnotes

† Please confirm element orientation. Improper position may result in heater or engine damage.

- 1) Remove and replace starter.
- 2) Pull or pry out core plug.
- 3) Replacement heater only. May require lower coolant return line (steel tube) - purchase from GM.
- 4) Remove and replace alternator.
- 5) Installation by certified mechanic recommended.
- 6) On some models, the air pump has to be loosened.
- 7) Remove right front wheel and splash guard.
- 8) Lower radiator hose heater: 1-3/4" dia. prior to 1970, 1-1/2" dia. later.
- 9) Lower radiator hose heater: 1970 & earlier—use 1-3/4" model; 1971-93—use 1-1/2" model.
- 10) Install in hose rise closest to water pump.
- 11) Lower radiator hose heater: 1977-82—use 1-1/4" model; 1983-85—use 1-1/2" model.
- 12) Lower radiator hose heater to 1993 only.
- 13) If LR is a 40mm core hole, install heater in 2nd LR.
- 14) Confirm with dealer on core hole type. Stepped core hole (1985-91). Normal style core hole (1991-96).
- 15) Kit contains a thermostatically controlled cord required for compatibility with the OBD 11 system in these vehicles.
- 16) May require mounting Elbow P/N 14075-AM700, Gasket P/N 11065-AM700 and Bolts P/N A1005H8, available from Nissan Infinity.